

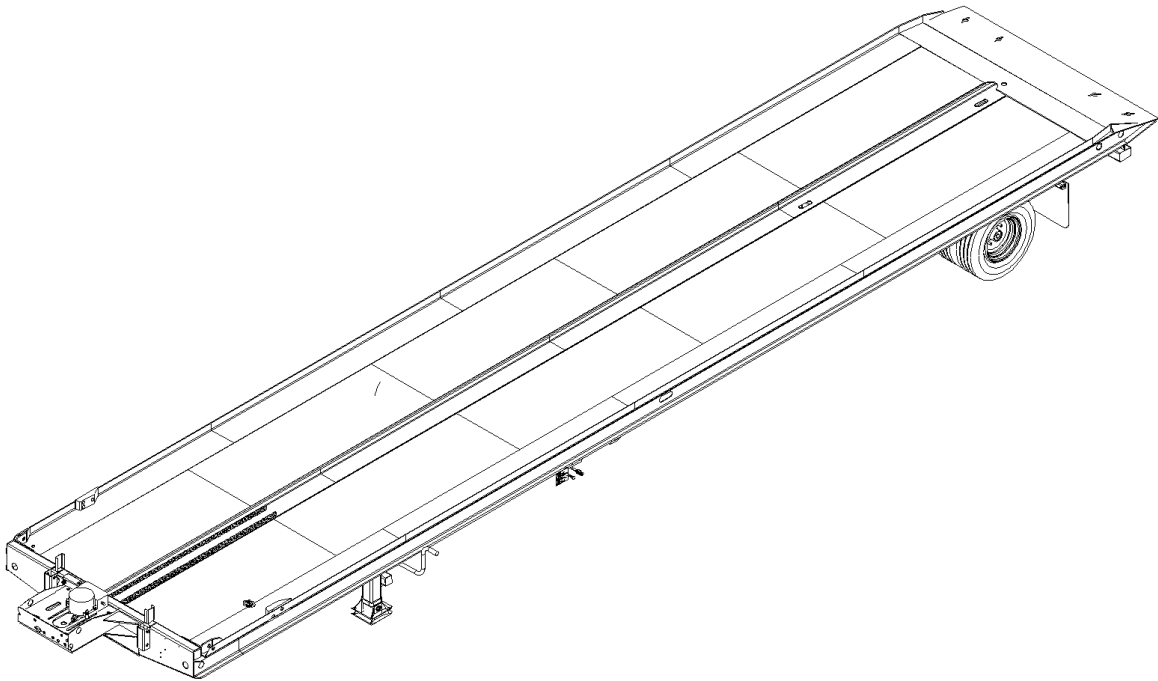

Model 330D Semitrailer Operator's Manual



LANDOLL COMPANY, LLC.

1900 North Street
Marysville, Kansas 66508
(785) 562-5381

800-428-5655 ~ WWW.LANDOLL.COM

Table of Contents

1	Introduction	
	Understanding Safety Statements	1-2
2	Standard Specifications	
	MODEL 330D Container	2-1
	Specific Bolt Torques	2-2
	Cam Follower Assembly	2-2
	Suspension Assembly, Air Ride	2-2
	Suspension Assembly, Spring Ride	2-2
	Wheel Fasteners	2-2
	Winch Fasteners (Option)	2-2
	General Torque Specifications	2-3
	SAE UNC Torque Specifications	2-3
	SAE UNF Torque Specifications	2-3
	Metric Torque Specifications	2-4
	Hydraulic Fitting Torque Specifications	2-4
	Aeroquip® Brand Fittings	2-4
	Gates® Brand Fittings	2-5
	Parker® Brand Fittings	2-5
3	Operating Instructions	
	General	3-1
	Air Brake System	3-1
	Anti-Lock Brake System (ABS)	3-1
	Pre-Coupling of Semitrailer and Tractor	3-2
	Coupling of the Tractor to the Semitrailer	3-2
	Connecting Tractor Services to the Semitrailer	3-3
	Tractor and Semitrailer Check-Out	3-3
	Towing the Semitrailer	3-4
	Parking the Semitrailer	3-5
	Uncoupling Tractor from Semitrailer	3-5
	Trailer Tilt Lever	3-6
	Axle Control Lever	3-6
	Gearbox Controls	3-6
	Winch Controls	3-6
	Loading Procedure	3-8
	Unloading the Trailer	3-12
	Remote Control (Option)	3-13
	Auxiliary Hydraulic Power Engine Operation	3-14
	Bulkheads	3-16
	Rear Impact Guard System	3-16
	Anti-Lock Brake System (ABS)	3-16
	Cold Weather Operation	3-17
	Hot Weather Operation	3-17
4	Maintenance and Lubrication	
	General	4-1
	Cold Weather Tips	4-1

TABLE OF CONTENTS

Hot Weather Tips	4-2
Maintenance Schedule	4-2
Cleaning	4-2
Inspection	4-3
Fluid Leak Classification	4-3
Inspection Overview	4-3
Lubrication	4-3
Repair Parts	4-3
Structural Defects	4-4
Wood Deck Care	4-4
Tools and Equipment	4-4
Torque Values	4-4
Lubrication & Maintenance Schedule	4-5
Lubrication Points	4-5
Lubricant Specifications	4-6
Trailer Maintenance Schedule	4-7
Trailer Maintenance Schedule Notes	4-8
Hydraulic Engine Maintenance Schedule (OPTION)	4-9
Air System Maintenance	4-10
Air System Maintenance Schedule	4-10
Hydraulic Maintenance	4-10
Fluid Leak Classification	4-10
Fluid Leak Classifications	4-10
Hydraulic Maintenance Schedule	4-11
Hydraulic Engine Package	4-11
Electrical System	4-11
Suspension Maintenance	4-14
Spring Suspension	4-14
Air Ride Suspension	4-15
Air Ride Height Adjustment	4-15
Alignment	4-15
Wheel Alignment	4-15
Axle Alignment	4-17
Alignment, Air Ride Trailer 1st Axle Procedure	4-17
Alignment, Air Ride Trailer 2nd & 3rd Axle Procedure	4-17
Alignment, Spring Ride Trailer 1st Axle Procedure	4-19
Alignment, Spring Ride Trailer 2nd & 3rd Axle Procedure	4-19
Brake System Maintenance	4-20
General	4-20
Spring Air Brake Chamber	4-21
Caging the Power Spring	4-22
Removal	4-22
Installation	4-22
Tandem Relay Valve Maintenance	4-22
Brake Assembly Maintenance	4-22
Brake Adjustment	4-23
Disassembly	4-23
Reassembly	4-23
Brake Adjustment	4-24
Disassembly	4-24
Reassembly	4-24
Hub and Drum Maintenance	4-25
Wheel Bearing Lubrication and Adjustment	4-27
Adjustment	4-27
Tire Maintenance	4-27

Tire Inflation	4-27
Tire Matching	4-27
Tape Measuring Method	4-27
Straight Edge or String Method	4-27
Mounting Tire and Wheel	4-28
Gearbox Maintenance	4-30
Winches	4-30

5 Troubleshooting Guide

Electrical	5-1
Tires - Wheels - Suspension	5-2
Brakes	5-4
Brake Drums	5-6
Hydraulic System	5-8
Hydraulic Power Supply Engine Package	5-10
Remote Control	5-12
Gearbox	5-14

TABLE OF CONTENTS

Introduction

This manual provides operating, servicing, and maintenance instructions for Model 330D Container semitrailer, manufactured by Landoll Company, LLC., Marysville, Kansas 66508.

- CHAPTER 1** gives basic instructions on the use of this manual.
- CHAPTER 2** gives product specifications for the trailer, including measurements and component specifications. A Standard Bolt Torque Table is provided to give guidelines for bolt torques to be used when servicing this product.
- CHAPTER 3** gives instructions for the proper operation of the equipment.
- CHAPTER 4** gives general maintenance procedures, a maintenance schedule, and a lubrication schedule. Improper maintenance will void your warranty.

IF YOU HAVE ANY QUESTIONS CONTACT:

**LANDOLL COMPANY, LLC.
1900 NORTH STREET
MARYSVILLE, KANSAS 66508**

**or phone:
(785) 562-5381 or
(800) 428-5655
or FAX:
(888) 527-3909**

- CHAPTER 5** is a troubleshooting guide to aid in diagnosing and solving problems with the trailer.
- PARTS MANUAL** is a separate manual showing the various assemblies, sub-assemblies, and systems. Refer to that manual when ordering Landoll replacement parts. Order parts from your Landoll dealer.
- WARRANTY** The Warranty Registration form is included with the product documents. Fill it out and mail it within 10 days of purchase.
NOTE: IMPROPER ASSEMBLY, MODIFICATION, OR MAINTENANCE OF YOUR LANDOLL MACHINE CAN VOID YOUR WARRANTY.
- COMMENTS** Address comments or questions regarding this publication to:
**LANDOLL COMPANY, LLC.
1900 NORTH STREET
MARYSVILLE, KANSAS 66508
ATTENTION: PUBLICATIONS -DEPT. 55**

Understanding Safety Statements

You will find various types of safety information on the following pages and on the machine signs (decals) attached to the vehicle. This section explains their meaning.

The Safety Alert Symbol means ATTENTION! YOUR SAFETY IS INVOLVED!



DANGER

Danger means a life-threatening situation exists. Death can occur if safety measures or instructions on this label are not properly followed.



WARNING

Warning means serious injury or death can occur if safety measures or instructions on this label are not properly followed.



CAUTION

Caution means serious equipment or other property damage can occur if instructions on this label are not properly followed.

IMPORTANT

Means that failure to follow these instructions could cause damage to the equipment or cause it to operate improperly.

NOTE

Make sure you read and understand the information contained in this manual and on the machine signs (decals) before you attempt to operate or maintain this vehicle.

The safety statements contained in this manual relate to the operation of the Model 330D Container semitrailer.

Standard Specifications

MODEL 330D Container	
CAPACITY*:	
SINGLE AXLE	16,000 LB. DISTR. - 10,000 LB IN 10 FT.
TANDEM AXLE	50,000 LB DISTR. - 20,000 LB. IN 10 FT.
KING PIN SETTING:	30" 18" ON 90° DROP
UNDERCARRIAGE TRAVEL:	10'-6"
STANDARD LOAD ANGLE:	12°
LOW LOAD ANGLE 48' (OPTION):	9-1/2°
<p>NOTE: Capacity ratings are frame capacities only. Actual load capacities may be restricted by factors such as gross axle weight ratings (GAWR) or state and federal regulations. Tires, brakes, axles, or wheels may also limit capacity.</p>	
HYDRAULIC HOOKUP:	
QUICK COUPLERS	FLAT FACE 3/4" BODY SIZE
MAXIMUM OPERATING PRESSURE	2500 PSI
OPERATING FLOW	20 GPM (25 GPM maximum), with a minimum reservoir size of 30 gallons, minimum of 3/4" diameter hoses, with a pressure relief on the hydraulic supply.
<p>NOTE: Tractor hydraulic power supply must be capable of operating at this pressure and flow rate and be equipped with a pressure relief valve set at this pressure.</p>	
ELECTRICAL HOOKUP:	7-WAY CONNECTOR
AIR HOOKUP:	COLOR CODED GLAD HANDS

Specific Bolt Torques

Cam Follower Assembly	Ft. lbs	Nm
4" CAM FOLLOWER (THREADS GREASED)	166 250	225 338
Suspension Assembly, Air Ride		
1-1/8" - PIVOT AND ADAPTER BOLTS (DESIGNATION ON BOLTHEAD) NEWAY HOLLAND NEWAY	800 550	1840 745
7/8" - PIVOT BOLT LOCK NUTS (THREADS DRY) - DEXTER CORP 7/8" - JAM NUTS (THREADS DRY)	425 - 440 150	575 - 595 205
3/4" - SHOCK ABSORBER NUT (THREADS DRY) DEXTER CORP HOLLAND NEWAY	150 - 175 150	575 - 595 205
3/4" - UPPER AIR SPRING NUT (THREADS DRY) DEXTER CORP HOLLAND NEWAY	40-45 35	55-60 47
3/8" - LOWER AIR SPRING BOLT (THREADS DRY) - DEXTER CORP	15 - 20	20 - 25
1/2" - LOWER AIR SPRING BOLT (THREADS DRY) DEXTER CORP HOLLAND NEWAY	25 - 30 35	28 - 70 47
3/4" - SHOCK ABSORBER NUT (THREADS DRY) DEXTER CORP HOLLAND NEWAY	150 - 175 150	575 - 595 205
1/2" - RIDE HEIGHT AIR VALVE CONTROL ROD & LINKAGE NUTS	50	67
1/4" - RIDE HEIGHT AIR VALVE & LINKAGE NUT (THREADS DRY)	5	7
Suspension Assembly, Spring Ride		
1" - TORQUE ARM BUSHING NUTS (THREADS OILED) 7/8" - TORQUE ARM BUSHING NUTS (THREADS OILED)	540 250	732 380
5/8" - TORQUE ARM CLAMP NUTS (THREADS OILED) 1/2" - TORQUE ARM CLAM NUTS (THREADS OILED)	130 55-60	176 75-81
7/8" - U-BOLT CLAMPS (THREADS OILED) 3/4" - U-BOLT CLAMPS (THREADS OILED)	300-350 310	407-475 420
Wheel Fasteners		
OUTER SPINDLE NUTS	250 - 400	339 - 541
HUB CAP AND GASKET	10 - 15	14 - 26
PILOT WHEEL NUTS	450 - 500	611 - 676
Winch Fasteners (Option)		
WINCH MOUNT BOLTS	159	215

General Torque Specifications

Standard: General Torque Specifications (rev. 4/97)

These tables provide tightening torques for general purpose applications when special torques are not specified on process or drawing. Assembly torques apply to plated nuts and cap screws assembled without supplemental lubrication (as received condition). They **DO NOT** apply if special graphite moly-disulfide or other extreme pressure lubricants are used. When fasteners are dry (solvent cleaned) add 33% to as received condition torque. Bolt head identification marks indicate grade and may vary from manufacturer to manufacturer. Thick nuts must be used on grade 8 cap screws. Use the value in [] if using prevailing torque nuts.

SAE UNC Torque Specifications						
UNC	SAE Grade 2		SAE Grade 5		SAE Grade 8	
SIZE	Ft-lbs.	Nm.	Ft-lbs.	Nm.	Ft-lbs.	Nm.
1/4-20	4 [5]	5 [7]	6 [7]	8 [9]	9 [11]	12 [15]
5/16-18	8 [10]	11 [14]	13 [13]	18 [18]	18 [22]	24 [30]
3/8-16	15 [19]	20 [26]	23 [29]	31 [39]	35 [42]	47 [57]
7/16-14	24 [30]	33 [41]	35 [43]	47 [58]	55 [62]	75 [84]
1/2-13	35 [43]	47 [58]	55 [62]	75 [84]	80 [100]	108 [136]
9/16-12	55 [62]	75 [84]	80 [100]	108 [136]	110 [137]	149 [186]
5/8-11	75 [94]	102 [127]	110 [137]	149 [186]	170 [212]	230 [287]
3/4-10	130 [162]	176 [220]	200 [250]	271 [339]	280 [350]	380 [475]
7/8-9	125 [156]	169 [212]	320 [400]	434 [542]	460 [575]	624 [780]
1-8	190 [237]	258 [321]	408 [506]	553 [686]	680 [850]	922 [1152]
1-1/8-7	270 [337]	366 [457]	600 [750]	813 [1017]	960 [1200]	1302 [1627]
1-1/4-7	380 [475]	515 [644]	840 [1050]	1139 [1424]	1426 [1782]	1933 [2416]
1-3/8-6	490 [612]	664 [830]	1100 [1375]	1369 [1864]	1780 [2225]	2413 [3017]
1-1/2-6	650 [812]	881 [1101]	1460 [1825]	1979 [2474]	2360 [2950]	3200 [4000]
1-3/4-5	736 [920]		1651 [2063]		2678 [3347]	

SAE UNF Torque Specifications						
UNF	SAE Grade 2		SAE Grade 5		SAE Grade 8	
SIZE	Ft-lbs.	Nm.	Ft-lbs.	Nm.	Ft-lbs.	Nm.
1/4-28	4 [5]	5 [7]	7 [9]	9 [12]	10 [12]	14 [16]
5/16-24	9 [11]	12 [15]	14 [17]	19 [23]	20 [25]	27 [34]
3/8-24	17 [21]	23 [28]	25 [31]	34 [42]	35 [44]	48 [60]
7/16-20	27 [34]	37 [46]	40 [50]	54 [68]	60 [75]	81 [102]
1/2-20	40 [50]	54 [68]	65 [81]	88 [110]	90 [112]	122 [152]
9/16-28	60 [75]	81 [102]	90 [112]	122 [152]	130 [162]	176 [220]
5/8-18	85 [106]	115 [144]	130 [162]	176 [220]	180 [225]	244 [305]
3/4-16	150 [188]	203 [255]	220 [275]	298 [373]	320 [400]	434 [542]
7/8-14	140 [175]	190 [237]	360 [450]	488 [610]	500 [625]	678 [847]
1-14	210 [263]	285 [357]	540 [675]	732 [915]	760 [950]	1030 [1288]
1-1/8-12	300 [375]	407 [508]	660 [825]	895 [1119]	1080 [1350]	1464 [1830]
1-1/4-12	420 [525]	569 [712]	920 [1150]	1247 [1559]	1500 [1875]	2034 [2542]
1-3/8-12	560 [700]	759 [949]	1260 [1575]	1708 [2135]	2010 [2512]	2725 [3406]
1-1/2-12	730 [912]	990 [1237]	1640 [2050]	2223 [2779]	2660 [3325]	3606 [4508]
1-3/4-12	920 [1150]		2063 [2579]		3347 [4183]	

Metric:

Coarse thread metric class 10.9 fasteners and class 10.0 nuts and through hardened flat washers, phosphate coated, Rockwell "C" 38-45. Use value in [] if using prevailing torque nuts

Metric Torque Specifications

Nominal thread diameter (mm)	Newton Meters	Foot Pounds
6	10 [14]	7 [10]
7	16 [22]	12 [16]
8	23 [32]	17 [24]
10	46 [60]	34 [47]
12	80 [125]	60 [75]
14	125 [155]	90 [115]
16	200 [240]	50 [180]
18	275 [330]	205 [245]
20	385 [450]	290 [335]
24	670 [775]	500 [625]
27	980 [1105]	730 [825]
30	1330 [1470]	990 [1090]
33	1790 [1950]	1340 [1450]
36	2325 [2515]	1730 [1870]
39	3010 [3210]	2240 [2380]

Hydraulic Fitting Torque Specifications

37 degree JIC, ORS, and ORB. (Hydraulic Fitting Torque Specifications (rev. 10/97))

This chart provides tightening torques for general purpose applications when special torques are not specified on process or drawing. Assembly torques apply to plated nuts and cap screws assembled without supplemental lubrication (as received condition). They **DO NOT** apply if special graphite moly-disulfide or other extreme pressure lubricants are used. When fasteners are dry (solvent cleaned) add 33% to as received condition torque. Bolt head identification marks indicate grade and may vary from manufacturer to manufacturer. Thick nuts must be used on grade 8 cap screws. Use value in [] if using prevailing torque nuts

Aeroquip® Brand Fittings

Dash Size	37 Deg. JIC		O-ring (ORS)		O-ring boss	
	Ft-lbs.	Nm.	Ft-lbs.	Nm.	Ft-lbs.	Nm.
-4	11-12	15-16	10-12	14-16	14-16	20-22
-5	15-16	20-22	-----	-----	16-20	24-27
-6	18-20	24-28	18-20	24-27	24-26	33-35
-8	38-42	52-58	32-35	43-47	50-60	68-78
-10	57-62	77-85	46-50	62-68	75-80	98-110
-12	79-87	108-119	65-70	88-95	125-135	170-183
-14	-----	-----	-----	-----	160-180	215-245
-16	108-113	148-154	92-100	125-136	200-220	270-300
-20	127-133	173-182	125-140	170-190	210-280	285-380
-24	158-167	216-227	150-165	204-224	270-360	370-490
-32	245-258	-----	-----	-----	-----	-----

Gates[®] Brand Fittings						
Dash Size	37 Deg. JIC		O-ring (ORS)		O-ring boss	
	Ft-lbs.	Nm.	Ft-lbs.	Nm.	Ft-lbs.	Nm.
-4	10-11	14-15	10-12	14-16	14-16	20-22
-5	13-15	18-20	-----	-----	-----	-----
-6	17-19	23-26	18-20	24-27	24-26	33-35
-8	34-38	46-52	32-40	43-54	37-44	50-60
-10	50-56	68-76	46-56	62-76	50-60	68-78
-12	70-78	95-105	65-80	88-110	75-83	98-113
-14	-----	-----	65-80	88-110	-----	-----
-16	94-104	127-141	92-105	125-142	111-125	150-170
-20	124-138	168-187	125-140	170-190	133-152	173-206
-24	156-173	212-235	150-180	204-244	156-184	212-249
-32	219-243	297-329	-----	-----	-----	-----

Parker[®] Brand Fittings						
Dash Size	37 Deg. JIC		O-ring (ORS)		O-ring boss	
	Ft-lbs.	Nm.	Ft-lbs.	Nm.	Ft-lbs.	Nm.
-4	11-13	14-18	15-17	20-23	13-15	18-20
-5	14-16	20-22	-----	-----	21-23	28-31
-6	20-22	27-30	34-36	46-49	25-29	34-39
-8	43-47	58-64	58-62	79-84	40-44	43-60
-10	55-65	75-88	100-110	136-149	58-62	79-84
-12	80-90	108-122	134-146	182-198	75-85	98-115
-16	115-125	156-169	202-218	274-296	109-121	148-164
-20	160-180	217-244	248-272	336-369	213-237	289-321
-24	185-215	250-292	303-327	411-443	238-262	323-355
-32	250-290	339-393	-----	-----	310-340	420-461

Table provided for general use.

NOTES:

Operating Instructions

General

This section supplies information for operation of the trailer. It describes and locates controls and gives general operation procedures. Read all instructions, warnings, cautions and danger notes before attempting to operate the trailer. Operators must have proper training before operating the semitrailer.

A hydraulic pump must be coupled to the trailer hydraulic system, or the optional hydraulic engine package started, before using hydraulic controls.



WARNING

Do not operate the semitrailer with any known fault that might endanger the occupants, nearby workers, other traffic, the load, or the equipment.



WARNING

Do not operate the semitrailer until you have read the operator's manual and completely understand the proper use and function of all controls. Improper use can cause personal injury, damage to your semitrailer and cargo, and cause time-consuming breakdowns.



CAUTION

The auxiliary (blue) circuit is for powering the semitrailer ABS. This circuit must be hot when the tractor key switch is on. No other electrical devices may be powered by this circuit while the semitrailer is moving forward.



CAUTION

If a fault exists in the semitrailer ABS, normal braking will occur, but wheels may lock. Service the ABS as soon as possible.

Air Brake System

The air brake system of the trailer is operated from the towing vehicle after coupling. The towing vehicle's air system must be coupled to the trailer and charged to 90 psi minimum before the brakes can adequately function.

Anti-Lock Brake System (ABS)

The Anti-Lock Brake System of the semitrailer is constant powered by the auxiliary (blue) circuit of the seven way electrical connector, with backup power from the stop lamp (red) circuit, and ground through the white wire. It is necessary that the blue circuit is hot when the tractor key switch is on. The blue circuit on the trailer may also not be used to power any additional auxiliary devices while the semitrailer is moving forward. If a fault exists in the ABS, normal braking will occur, but the wheels may lock. Service the ABS as soon as possible.

Pre-Coupling of Semitrailer and Tractor

1. Slowly back the tractor up to the front end of the semitrailer so the kingpin of the semitrailer is centered between the tractor fifth wheel jaws. Stop the tractor several inches ahead of the semitrailer. Set tractor parking brake.
2. The king pin plate should be the same height as, or slightly lower than, the latch area of the fifth wheel plate of the tractor. If necessary, connect the tractor hydraulic lines or start the trailer hydraulic power engine. Use the **TRAILER TILT** lever to raise or lower the kingpin plate sufficiently to allow proper coupling (See **Figure 3-2.**) Drain all air and moisture from the tractor air brake system in accordance with the tractor manufacturer's instructions.
3. Connect the service and emergency air hoses of the tractor to their respective gladhand on the front of the semitrailer. The tractor's air hose couplings are then attached and locked to the appropriate gladhands; the **red emergency line** to the gladhand with the "**EMERGENCY**" tag, and the **blue service line** to the gladhand with the "**SERVICE**" tag (See **Figure 3-1.**) Chock the semitrailer wheels before activating the semitrailer air supply valve in the tractor. Set the semitrailer brakes.
4. Check the air brake operations of the semitrailer as follows:
 - a. Apply brakes and inspect brake action on all wheels for prompt application.
 - b. Release brakes. All brakes should release immediately. Air pressure should discharge quickly from the relay emergency valve.
 - c. Disconnect the emergency air line from the semitrailer gladhand. Semitrailer brakes should promptly set.
 - d. Reconnect the emergency air line to the semitrailer and activate the semitrailer air supply valve. The semitrailer brakes should set.

Coupling of the Tractor to the Semitrailer



DANGER

Keep all personnel clear of front, rear, and sides of tractor and semitrailer during coupling, component operations, and uncoupling. Failure to stay clear can result in serious personal injury or death.

1. Verify the semitrailer wheels are chocked and brakes function properly.
2. Make sure the tractor's fifth wheel coupler is open.
3. Slowly back the tractor so its fifth wheel contacts the front of the kingpin plate on the semitrailer and slips under it. Continue backing until the fifth wheel coupler locks onto the semitrailer kingpin.
4. Try to pull the tractor forward a few inches to verify the vehicle coupling is secure. If the tractor disconnects from the semitrailer: locate the source of the coupling failure; repair before continuing; and repeat **steps 3 and 4.**



CAUTION

Pushing semitrailer backwards can damage landing gear.

5. Check that the tractor couples securely to the semitrailer before setting tractor and semitrailer parking brakes.

IMPORTANT

Keep brakes engaged for remainder of coupling, check-out, and parking.

Connecting Tractor Services to the Semitrailer

1. Connect the tractor 7-way electrical plug to the electrical receptacle on the front of the semitrailer (See Figure 3-1.)

IMPORTANT

The key on the plug and the keyway in the socket must be properly aligned before inserting the plug into the semitrailer socket.

2. If you have not already done so, connect the tractor hydraulic lines to the semitrailer, unless your semitrailer is equipped with the auxiliary hydraulic power engine package.

IMPORTANT

Some oil may need to be removed from the tractor reservoir to allow room for 12 gallons of additional oil displaced from the semitrailer hydraulic system.

Tractor and Semitrailer Check-Out

1. While hydraulic power is operating, raise the front end of the semitrailer with the **TRAILER TILT** lever until weight is off the landing gear (See Figure 3-2.) Raise landing gear. Secure each leg with a park stand retaining pin in fully retracted position before transporting.

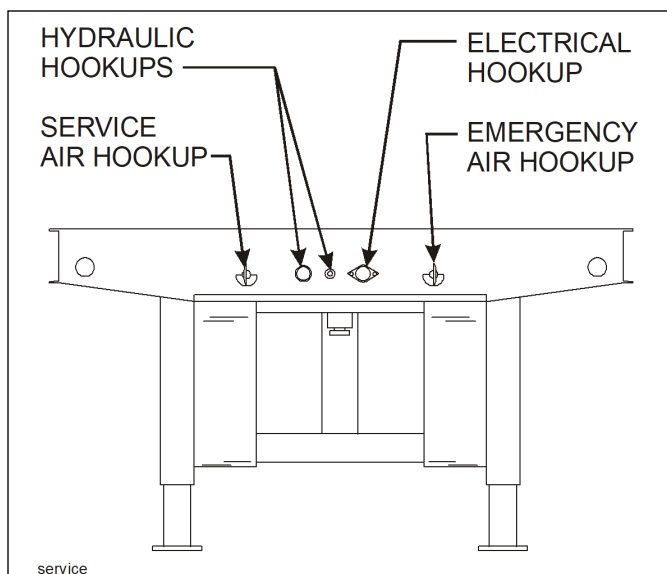

Figure 3-1: Service Hookups (Front View)

! WARNING

Landing gear legs must be fully retracted and secured with pins before operating or moving semitrailer.

2. Lower the front end with the **TRAILER TILT** lever until the semitrailer is fully lowered. Hold lever in the down position until hydraulic system works against the bottomed out hydraulic tilt cylinders.
3. Verify that the traveling undercarriage is completely slid back to transport position. Shut off hydraulic power.
4. Check the operation of all lights and signals on the semitrailer for proper response to switch positions (stop, right turn, left turn and clearance).
5. Check that tire inflation matches the pressure listed on the tire.
6. Check tractor/semitrailer combination for air leaks. If air leakage is found, repair the defect before transporting.
7. Check that the oil in each hub is at the proper level and free from contamination. If hubs contain water, dirt, or other foreign matter, clean them before transporting.
8. Check tractor air pressure. Pressure must not fall below 65 psi, even after activating brakes a couple of times. Set parking brake and carefully remove all wheel chocks. Set emergency brake and try pulling forward. The semitrailer wheels must not rotate. If semitrailer brakes do not apply, do not transport until defect, or defects, are repaired.

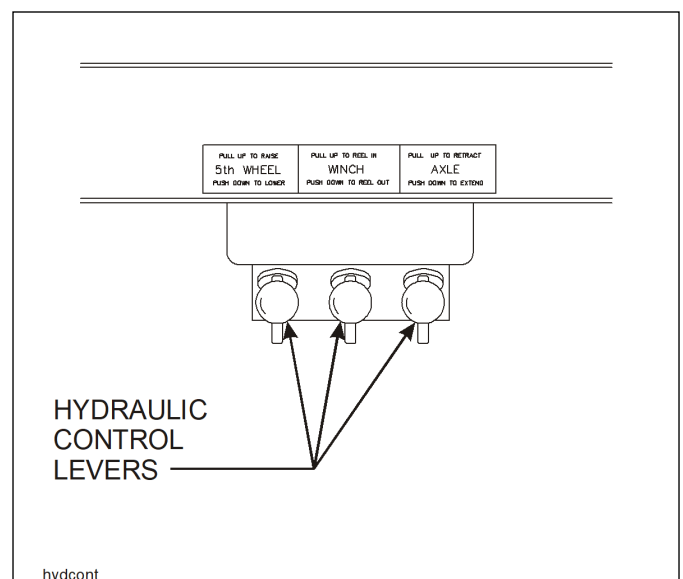

Figure 3-2: Hydraulic Control Levers

Towing the Semitrailer

1. Driving the tractor with the semitrailer coupled behind requires constant attention to the overall length. Turning, passing, accelerating, braking, stopping, and back-up require special considerations. When executing steep grades or turning tight curves, the semitrailer must not be allowed to push the tractor, or jackknifing may result. Application of the semitrailer brakes to keep the semitrailer in tow will help prevent this situation. To assure control, brake before descending a hill or attempting a curve.
2. Make a moving test of the semitrailer brakes at low and medium speeds **before** traveling at highway speed.
 - a. The Anti-Lock Brake System (ABS) warning lamp mounted at left rear side of the trailer should come on when power is supplied to the ABS by turning the tractor key switch on. The warning lamp should go off once the trailer exceeds 4 mph. If the warning lamp does not go off, a fault exists in the trailer ABS. Once the vehicle speed exceeds 4 mph, the light should remain off unless a fault occurs or the key switch is turned off, then on again.

3. Monitor the air pressure gauge on the dash of the tractor. Pressure should not fall below 90 psi at any time.



CAUTION

When operating trailer, do not back over curb. This will cause severe damage to undercarriage and undercarriage cylinder.

4. The semitrailer wheels track to the inside of the tractor during turns. Thus, turning corners requires a wide swing to prevent “curb hopping”, and to allow the semitrailer wheels to clear any obstacle on the inside of the corner.
5. To stop, use a gradual and smooth application of brakes. If grabbing occurs, apply less pressure. Grabbing brakes are not efficient.



DANGER

Always check behind and under the tractor and semitrailer for persons or objects before moving. Failure to check can lead to serious personal injury, death, or damage to property.

6. Backing should be done with care. Tail overhang, semitrailer length, and allowable space must be taken into consideration.

Parking the Semitrailer

1. Position tractor/trailer rig on a level, solid surface.
2. Set the **PARKING BRAKE**, not the **semitrailer emergency hand brake**, and check for proper brake holding.
3. Chock wheels.
4. Check for any air leaks in lines, relay valve, brake pods, or any other air system component.



WARNING

When leaving the semitrailer unattended, position all hydraulic controls to the neutral or “off” position and shut off the hydraulic engine power supply, or disconnect the tractor hydraulic hook-up.

Uncoupling Tractor from Semitrailer

1. Park the semitrailer according to instructions in “**Parking the Semitrailer**” on page 3-5.
2. Remove retaining pin and lower landing gear to the ground. Hydraulically raise the front end of the semitrailer until the next hole in the landing gear is available. Insert pin through both inner and outer legs of the landing gear. Hydraulically lower semitrailer onto the legs.



WARNING

Secure each leg with pin before leaving semitrailer unattended.

3. Pull the tractor fifth wheel plate latch release.
4. Disconnect emergency and service air lines and attach them to the tractor gladhand holders.
5. Disconnect the 7-way cable and hydraulic lines from the semitrailer and store with the tractor.
6. Attempt to pull the tractor forward. If the tractor uncouples, verify that all service lines are disconnected and semitrailer wheels are chocked. If tractor does not disconnect, repeat **steps 5 and 6**.
7. Pull the tractor away from the semitrailer.

Trailer Tilt Lever

The **TRAILER TILT** lever is located on the driver's side of the semitrailer under the outer frame beam (See **Figure 3-2.**) It has three positions:

UP	In this position, the front end of the semitrailer rises to the load position.
CENTER	This is the neutral position. The semitrailer stays in its current position.
DOWN	In this position, the front end of the semitrailer lowers to the transport position.

Axle Control Lever

The **AXLE CONTROL** lever is the control on the rear with three positions (See **Figure 3-2.**):

UP	In this position, the undercarriage slides forward for loading.
CENTER	This is the neutral position.
DOWN	In this position, the undercarriage slides to the rear. The undercarriage must be in the rear-most position for transport.

Gearbox Controls

The **HYDRAULIC GEARBOX (WINCH) CONTROL** lever is the center lever (See **Figure 3-2.**) It is a three position control:

UP	In this position, the chain rotates counterclockwise.
CENTER	This is the neutral position.
DOWN	In this position, the chain rotates clockwise.

Winch Controls



DANGER

1. The winch is not designed or intended to be used for lifting or moving people. Using it this way can cause serious injury or death.
2. Never attempt to disengage the winch cable spool when the cable is under tension. Loss of load control, property damage, injury or death can result.
3. Failure to leave at least five winch cable wraps on the winch cable spool could allow the cable to come off the spool, resulting in serious personal injury or death.

1. The **WINCH CLUTCH** is on the curbside of the winch assembly. It engages or disengages the winch.
 - a. The **12,000#** winch clutch handle must be pulled out to change positions and pushed in to lock into one of two positions (See **Figure 3-3.**):

DOWN	This position, the winch is disengaged and the cable can "free-wheel".
UP	In this position, the winch is engaged and the cable can be "power" spooled in or out. The winch is now controlled by the WINCH hydraulic lever.

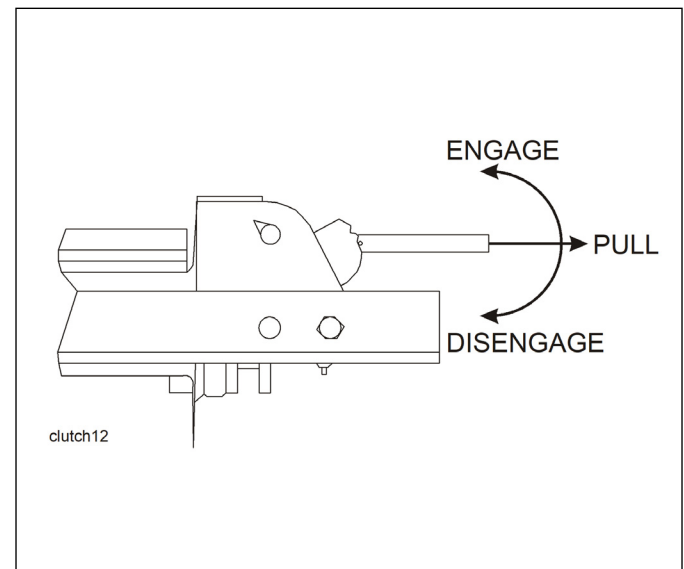

Figure 3-3: 12,000# Winch Clutch

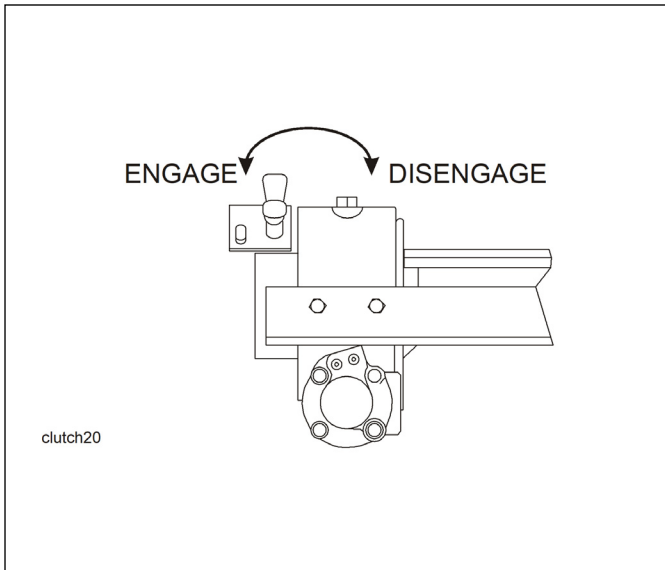

Figure 3-4: 20,000# Winch Clutch

- b. The **20,000#** winch clutch handle has two positions (**See Figure 3-4.**):

RIGHT	This position, the winch is disengaged and the cable can “free-wheel”.
LEFT	In this position, the winch is engaged and the cable can be “power” spooled in or out. The winch is now controlled by the WINCH hydraulic lever.

- c. The **HYDRAULIC WINCH CONTROL** lever is the center lever (**See Figure 3-2.**) It is a three position control:

UP	In this position, cable is “power” spooled onto the spool.
CENTER	This is neutral position.
DOWN	In this position, cable is “power” spooled off the spool.

Loading Procedure

1. Practice all standard industrial safety standards (See **Figure 3-9.**) Do not load any payload that will overload any component of the semitrailer or cause any unsafe condition.
2. Proper operation requires that the undercarriage be pulled fully forward to create lowest low load angle.
3. Park the tractor/semitrailer in a straight line on level even surface. Set the tractor brakes and release the semitrailer brakes (See **Figure 3-9.**)
4. Start operation of hydraulic power system. If the hydraulic engine package is installed, start and warm up engine following engine operating instructions in “**Auxiliary Hydraulic Power Engine Operation**” on page 3-14 (Read engine operator’s manual.)
5. Alternate between moving the undercarriage forward and tilting the front of the bed up until the undercarriage is fully forward and the approach plate is on the ground. The weight of the semitrailer bed should rest partly on approach plate and partly on undercarriage. The object is to have the approach plate resting on the ground whenever the center of gravity of the semitrailer and load is behind the rear axle of semitrailer. In loading position, the approach plate should be resting on the ground and the undercarriage fully forward.



CAUTION

Do not allow the back semitrailer axle to leave the ground. This can result in damage to the semitrailer.



WARNING

In loading or unloading position, the approach plate should be resting on the ground and the undercarriage fully forward.



WARNING

Always use low load angle to load and unload powered products.

IMPORTANT

Steps 6 thru 12 describe general loading procedures for the semitrailer. Steps after are more specific operation procedures for loading containers.

6. Winch or drive the load onto the semitrailer. Insure that the load is steering straight up onto the semitrailer and does not maneuver off the side of the semitrailer. Continue until load center of gravity is just ahead of the axles. The load should never place more weight on the kingpin than on the rear axles during loading and unloading.



CAUTION

Maximum concentrated load is 10,000 lbs. in a 10 ft. area for a single axle semitrailer.



WARNING

1. The semitrailer must be coupled to a tractor and the landing gear raised off the ground before operating.
2. Do not exceed the gross axle weight ratings for any axle on your vehicle. The combined weight of the semitrailer and cargo must not exceed the gross vehicle weight rating (GVWR) of the trailer.



WARNING

The center of gravity of the load must be in front of the center of the undercarriage whenever the approach plate is not supported by the ground. Failure to do this can cause the semitrailer to tilt back resulting in injury or death.

7. If the load center of gravity is not ahead of the rear axle, alternate between tilting the front of the bed up and moving the undercarriage to the rear, until the center of gravity of the semitrailer load is in front of the rear axle. Keep part of the load on the wheels and part on the approach plate. Never move the undercarriage so far to the rear that the approach plate is lifted off the ground during this procedure.

8. When the center of gravity of the semitrailer and load is in front of the rear axle, fully lower the tilt angle.
9. After bed tilt angle is fully lowered, move the undercarriage to the rear until it is in transport position. Hold **TRAILER TILT (5TH WHEEL)** lever in the down position until hydraulic system works against the bottomed out Hydraulic Tilt Cylinders. Hold **AXLE CONTROL** lever in the transport position until hydraulic system works against the fully extended hydraulic axle cylinder.
10. If necessary, unsecure the load, move load slightly forward or rearward on the load bed to get correct weight distribution on kingpin and the semitrailer axles, and resecure the load with the tiedowns and winch cable.
11. Shut down the auxiliary hydraulic power engine following operating instructions in “**Auxiliary Hydraulic Power Engine Operation**” on page 3-14.
12. Recheck that the load is properly secured. Assure maintenance schedule is up-to-date and semitrailer is ready to be pulled.
13. The gearbox operates a chain drive that makes a continuous loop from front of trailer to the rear of trailer. The gearbox can move the chain either clockwise or counterclockwise.
14. Check the container to be loaded to see if the container front corner castings are an inch or so off the ground. If they are not, the container will have to be lifted first and blocks placed a few inches behind front of container to keep container an inch or so off the ground (**See Figure 3-5.**)
 - a. The trailer can be used to lift empty containers. The trailer should be straight in front of container and as close to container as possible without hitting container.
 - b. Operating trailer using the same methods described earlier in this section, move the undercarriage forward a couple feet and tilt the front of trailer up fully.
 - c. Connect the container chain harnesses provided with trailer to the container corner castings (**See Figure 3-6.**)
 - d. Connect the chain adapter with chain hook onto the gearbox drive chain.
 - e. Connect chain hook into another chain with hook which connects into center of container chain harness.
 - f. Operate the gearbox to tighten the chain. **See “Gearbox Controls” on page 3-6** for gearbox operating instructions.
 - g. Tilt the trailer down until the front of container is lifted enough to block up an inch or so.

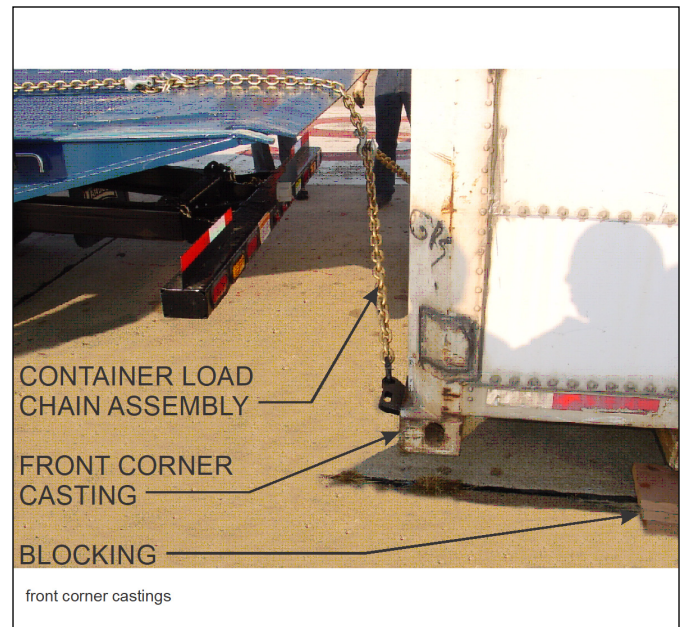

Figure 3-5: Front Corner Castings

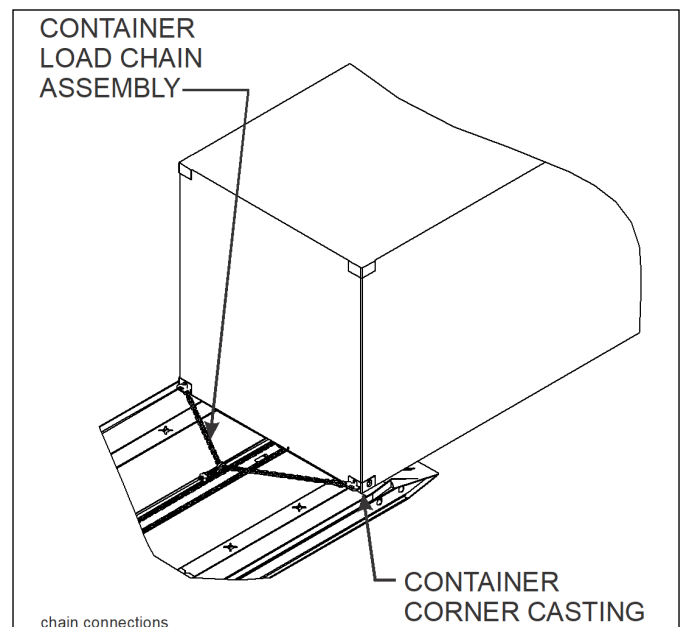

Figure 3-6: Chain Connections

15. Pull undercarriage forward and tilt the rear of trailer to within a half inch off the ground.
 - a. Move trailer back under front of container a few inches.
 - b. Tighten chain attached to container by operating gearbox.
 - c. The truck and trailer can be pulled under container by releasing both truck and trailer brakes, but make sure either the container or trailer approach plate is always on the ground so the truck and trailer do not roll away freely. An operator needs to be in the truck to apply the brakes just in case the truck and trailer do start to roll away freely.
 - d. Operate gearbox until container is on trailer five feet.
 - e. The chain with hook can now be removed and the container chain harness connected directly to chain adapter with chain hook. This will allow the container to be pulled onto trailer.
 - f. Install stop pins in lower front hole of blocks at front sides of trailer (**See Figures 3-7 and 3-8.**)
 - g. Pull container up to pin stops.
 - h. Insert hold-down pins into rear holes of blocks at front sides of trailer (**See Figures 3-7 and 3-8.**)
 - i. Use straps to secure container to trailer at least every ten feet.
16. Use the same procedure for returning the loaded trailer back to transport as described in **steps 9 through 12.**

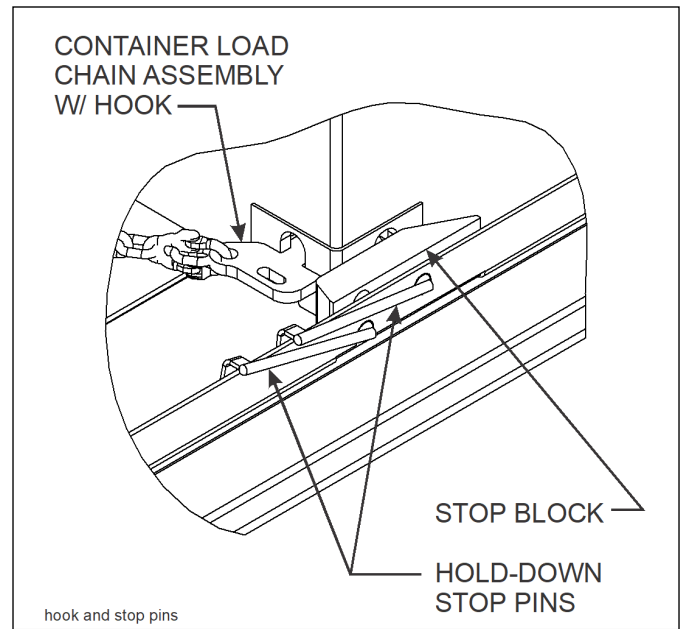

Figure 3-7: Container Load Chain and Stop Pins

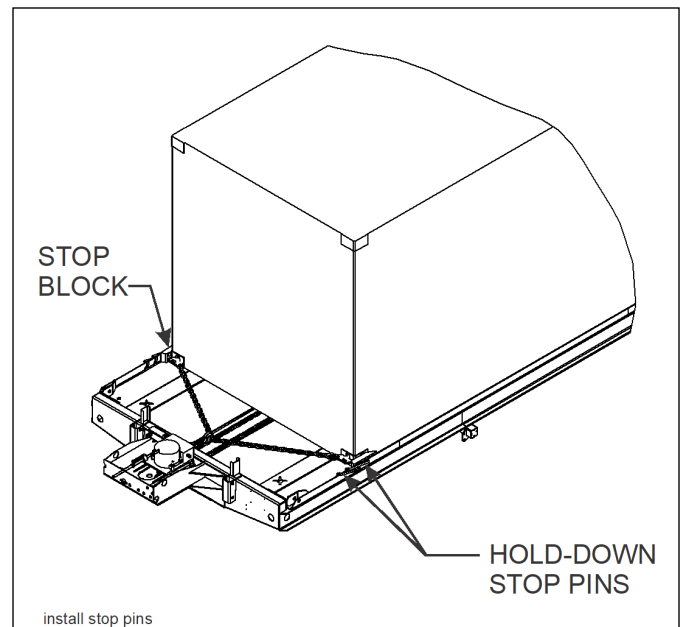
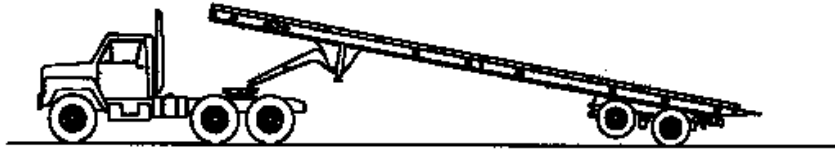

Figure 3-8: Installing Stop Pins

LOADING



⚠ WARNING: ALWAYS USE LOW LOAD ANGLE TO LOAD AND UNLOAD POWERED PRODUCTS.

⚠ WARNING: CENTER OF GRAVITY OF LOAD MUST REMAIN AHEAD OF SUSPENSION CENTER WHEN APPROACH PLATE IS NOT SUPPORTED BY GROUND.

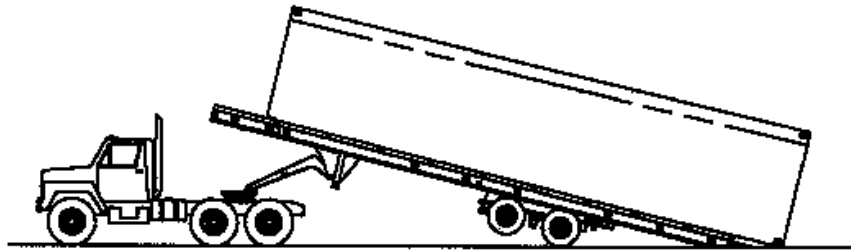

⚠ CAUTION: DO NOT ALLOW BACK AXLE TO LEAVE THE GROUND.

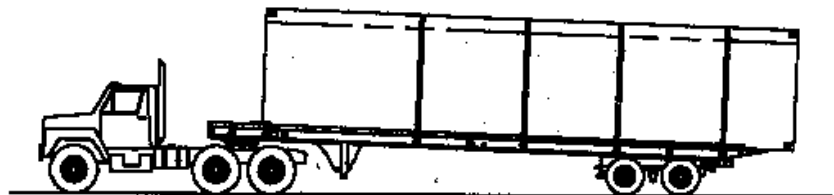
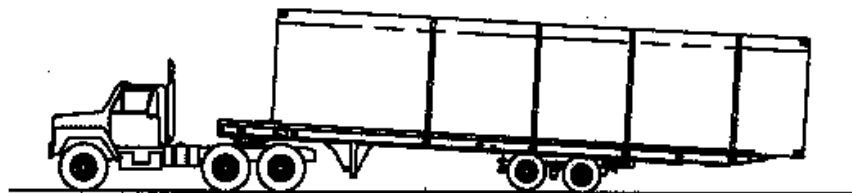

UNLOADING

3ma410-011503

Figure 3-9: Steps for Loading and Unloading

Unloading the Trailer



WARNING

Never tilt the trailer without the load properly restrained. Failure to do so may result in the load moving resulting in serious personal injury, death, or damage to property in it's path.



WARNING

Do not pull the rear axle of trailer farther forward than the center of gravity of the payload when rear approach plate is off the ground. Failure to operate correctly can allow front of trailer to go up and pull towing truck off the ground resulting in serious personal injury, death, or damage to property in its path.

1. Practice all standard industrial safety standards (See **Figure 3-9.**)
2. Park towing vehicle and trailer on relatively level ground.
3. Set towing vehicle's brakes.
4. Engage the P.T.O. or start the hydraulic power engine.

IMPORTANT

Steps 5 thru Steps 10 describe general unloading procedures for the semitrailer.

5. Alternate between raising the trailer and pulling the axles forward until the approach plate touches the ground. Never pull the axles forward so far that center of gravity of the load and trailer are behind the rear axle of the trailer unless the approach plate is on the ground. Always use low load angle to unload powered products. To achieve low load angle, the undercarriage has to be all the way forward. The object is to keep a part of the weight on the approach plate, and part of the weight on the wheels while lowering the tilt angle. The maximum load angle is only intended, if required, for unloading non-powered products and to transfer load to tractor. Transfer load to tractor by raising deck and moving axles toward rear until load is forward of the rear axle, thus transferring load to tractor.

6. If load is non-powered, insure that the gearbox drive chain is firmly attached to the load and tension is on the chain. Tilt trailer according to **step 5.** With chain firmly attached to load, remove other load securing devices. Use the gearbox to assist the load down to the end of the approach plate. With end of load resting on the ground, block load from rolling or sliding, if necessary. Disconnect the chain connectors and move the trailer from under the load, allowing the load to move off trailer to the ground.



WARNING

When removing load, insure that the load is steering straight so it does not maneuver off the side of the trailer. Failure to do so could result in damage to equipment, injury, or death.

7. If load is powered, tilt trailer according to **step 5.** Make sure the trailer tilt is at the lowest load angle. Remove safety secure devices. Take tension off gearbox drive chain and remove chain connectors. Power load off the trailer.
8. Before returning the trailer to transport position, insure that there is sufficient distance between the load and the rear of the trailer so that the trailer does not hit the load when being folded back to transport position.



CAUTION

Before returning the trailer to transport position, insure that there is sufficient distance between the load and the rear of the trailer. Failure to do so may result in damage to the trailer and/or load.

9. Tilt the bed down and move undercarriage rearward to transport position. Hold **TRAILER TILT (5TH WHEEL)** lever in the down position until hydraulic system works against the bottomed out Hydraulic Tilt Cylinders. Hold **AXLE CONTROL** lever in the transport position until hydraulic system works against the fully extended hydraulic axle cylinder.
10. Disengage the P.T.O. system of tractor or shut off the hydraulic power engine.
11. The unloading of containers is similar to unloading other loads. The procedures for getting the trailer ready to unload are the same.
12. Use the same procedure for returning the trailer back to transport as described in **steps 8 and 9.**

Remote Control (Option)

1. A wireless six function radio remote control is available (See Figure 3-10.)
2. The wireless radio remote has six momentary push button switches that operate the functions as labeled on the hand held remote.

3. Specifications:

RF: 902-928 MHz FHSS 10mW

Temperature: Receiver: -40° to +85° C
 Transmitter: -20° to +60° C

Output Rating: 5 Amps each (sourcing)
 20 Amp system maximum

Encapsulated electronics inside receiver.

Transmitter IP-66

Power: 3.7V LiPo battery

Battery Life: 30 - 40 hours continuous

4. To operate the remote:

- a. Press and hold the POWER button for at least 2 seconds and release.
- b. The transmitter is designed with a power saving feature which turns the transmitter off after 15 minutes if no buttons are pressed.
- c. There are red and green LED's both on the keypad of the transmitter and inside the receiver case. The green LED will blink 2 times per second when the transmitter and receiver are communicating. It will blink 1 time per second if there is no communication (i.e. - no power to the receiver).
- d. The red LED on the transmitter and in the receiver will blink if there is a shorted or open output. Refer to **Table 3-1** and **Table 3-2** and count the number of blinks to determine the output with the fault.
- e. The transmitter's red LED blinks 1 time per second if the batteries are low and need to be replaced. To confirm a low battery condition, turn the receiver off and leave the transmitter on. If the transmitter red LED continues to blink, the battery is low and requires replacement. If the red LED blinks only when the receiver is on, there is a fault with one or more outputs, as stated above.
- f. The red LED will stay on while charging and when the charge is completed the green LED will stay on.
- g. It will take longer to charge if the transmitter is on during charging.

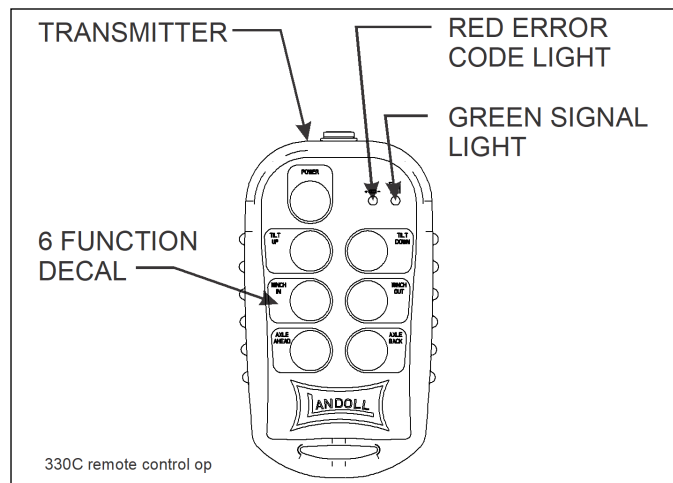

Figure 3-10: Remote Control Transmitter

Transmitter Error Code Chart	
Error Code	Probable Cause
1	Low Battery
2	Tilt Down Fault
3	Tilt Up Fault
4	Winch Out Fault
5	Winch In Fault
6	Axle Back Fault
7	Axle Ahead Fault

Table 3-1: Transmitter Error Code Chart

Receiver Error Code Chart	
Error Code	Probable Cause
1	RF Communication Problem
2	Tilt Down Fault
3	Tilt Up Fault
4	Winch Out Fault
5	Winch In Fault
6	Axle Back Fault
7	Axle Ahead Fault

Table 3-2: Receiver Error Code Chart

5. Synchronizing transmitter and receiver:

There are over 64,000 different addresses (id codes) available for each transmitter and receiver pair. Each transmitter and receiver pair is synchronized together at the factory. If a new transmitter is needed, synchronizing is required. Use the following procedure:

- With power applied, press the red button on the receiver for >5 seconds until LED's toggle.
- With the transmitter off, press and hold the POWER button for >10 seconds until LED's blink, then release.
- Wait for a few seconds until the green LED's begin to blink.
- Teach complete.

IMPORTANT

On winches with the air tension option, the winch tension is engaged automatically when the switch is turned to winch in/out. The winch tension switch on either the remote or the control panel must be used to disengage the winch.

Auxiliary Hydraulic Power Engine Operation

- The Hydraulic Power Supply Engine is used to power the hydraulic functions, should the tractor not be equipped with hydraulic hookups.

IMPORTANT

- Check the following fluid levels before starting the engine package: engine oil, fuel supply, hydraulic oil. (Check oil level while semitrailer is not tilted as tilting will change the oil level in the tank.)
- If the engine does not crank, check the following on the battery: charge, fluid, terminals, and cables. Take corrective actions as needed.



CAUTION

If the hydraulic fluid level is low during operation, the semitrailer may not operate correctly, resulting in damage to the semitrailer.

- The Engine Ignition Switch, Choke and Throttle are on the Engine Control Panel mounted on the drivers side of the engine package (See Figure 3-11.)

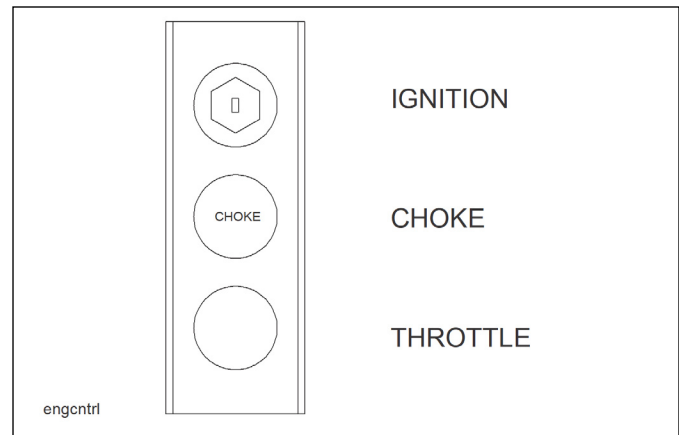

Figure 3-11: Engine Control Panel

- The **HYDRAULIC POWER SUPPLY ENGINE THROTTLE** controls the speed at which the engine operates (See Figure 3-11.) It is a variable position control:

HIGH	In this position, the engine throttle is fully open, letting it run at full speed.
LOW	In this position, the engine throttle is closed, letting the engine run at a slow idle.

- To start pull the choke completely out and set the throttle to the LOW position.
- Turn the ignition key to the START position. The engine should crank and then start.



CAUTION

Do not crank engine for more than 30 seconds. If engine does not start consult the owner's manual supplied with the engine.

- When the engine starts, release the key. Gradually push the choke lever in until the engine runs smoothly.
- Black smoke from the exhaust and a rough running engine usually indicate over-choking.
- To adjust the speed, turn the throttle control in or out, as needed, until the engine runs smoothly at a speed capable of withstanding use of the hydraulic controls. The hydraulic controls should now be functional.
- Before shutting it off, allow the engine to cool down by running at a slow idle for one to two minutes. Then turn the ignition switch to the off position.
- Once the engine is cool, turn or push the throttle and choke control completely in and turn the key to the OFF position.

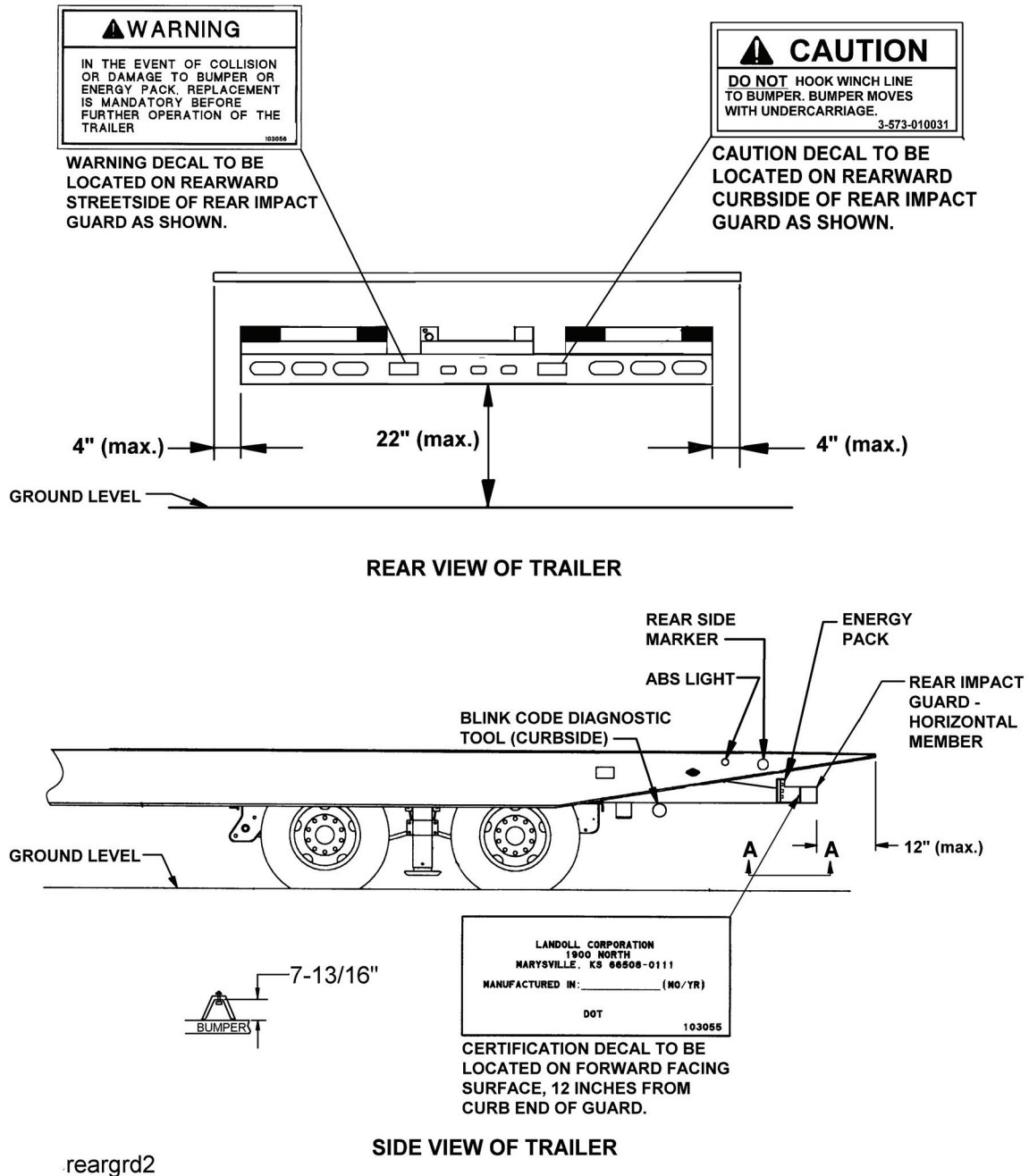

Figure 3-12: Rear Impact Guard System

Bulkheads



DANGER

To avoid serious injury all removable attachments must be firmly attached with fasteners provided at all times.

To remove a bulkhead, take out the pins holding bulkhead into the pockets on the semitrailer front and lift the bulkhead off.

Rear Impact Guard System

Vehicle standards FMVSS No. 224, Rear Impact Protection, requires all 330 semitrailers manufactured after January 26, 1998 shall be equipped with a rear impact guard certified by the manufacturer as meeting FMVSS No. 223, Rear Impact Guards. The guard, or bumper, meets the following requirements:

- a minimum of 4 inches vertical height
- extend laterally to within 4 inches of the sides of the trailer
- have a ground clearance of no more than 22 inches
- be placed no more than 12 inches from the rear of the trailer

The standard also specifies minimum force and energy absorption requirements for the guard. A DOT decal certifies that the guard meets FMVSS No. 223 and 224 standards. The decal is placed **and must remain at all times** on the forward facing surface of the guard, 12 inches inboard of the curb side and of the guard. See **Figure 3-12** for location of decals.

Replace any component that does not allow the above minimum requirements to be met. Any hardware that holds the rear impact guard and becomes damaged or becomes loose shall be removed and replaced. The 3/4" grade 8 screws that hold the bumper energy pack shall be loctited and torqued to 280 ft.-lbs.



DANGER

Always check the condition of the rear bumper energy pack. If pack has been damaged, it must be replaced. Failure to maintain energy pack may result in injury or death to others.

Anti-Lock Brake System (ABS)

Vehicle standards FMVSS No. 121, anti-lock brake system requires all trailers with air brake systems to have ABS after March 1, 1998. Each trailer (including a trailer converter dolly) shall be equipped with an anti-lock brake system that controls the wheels of at least one axle of the trailer. Wheels on other axles of the trailer may be indirectly controlled by the anti-lock brake system.

NHTSA Docket 92-29; notice 11 published September 23, 1996 specifies the ABS warning light be mounted near the rear of the left side of the trailer (See **Figure 3-12.**)

- decal or lens marking with ABS to identify the lamp
- the lamp must illuminate one time whenever power is supplied to the ABS. At any time the light remains on when power is supplied there is a malfunction to the system.

The ABS used on the semitrailer is a commercial unit. Single axle trailers use a two sensor, one modulator system. Tandem and triple axle semitrailers use a four sensor, two modulator system. Sensors are located at each hub of the front and rear axles, and each modulator controls one side of the trailer.

The ABS is constant powered by the auxiliary (blue) circuit, center pin on the semitrailer seven way electrical connector. This circuit must be hot whenever the tractor key switch is on. This circuit must also not be used to power any additional electrical devices while the semitrailer is moving forward. However, additional devices such as remote controls may be powered from the auxiliary circuit while the semitrailer is stationary. Back up power to the ABS is supplied through the stop lamp (red) circuit, No. 4 pin on the seven way connector, and ground is supplied by the white wire, No. 1 pin.



CAUTION

The auxiliary (blue) circuit is for powering the semitrailer ABS. This circuit must be hot when the tractor key switch is on. No other electrical devices may be powered by this circuit while the semitrailer is moving forward.

Malfunction in the ABS is signaled by illumination of the ABS warning lamp located at the left rear side of the semitrailer. The warning lamp will come on and stay on while power is supplied to the ABS on a moving vehicle, if there is a fault. If a fault in the ABS exists, normal braking will still occur, but wheels may lock. The semitrailer is still operable, but the system should be serviced as soon as possible.



CAUTION

If a fault exists in the semitrailer ABS, normal braking will occur, but wheels may lock. Service the ABS as soon as possible.

Cold Weather Operation

1. Cold weather causes lubricants to congeal, insulation and rubber parts to become hard, which may lead to problems found in bearings, electrical systems, and air systems. Moisture attracted by warm parts can condense, collect and freeze to immobilize equipment. The truck/trailer operator must always be alert for indicators of cold weather malfunctions.
2. During any extended stop period, neither the service nor parking brake should be used as they can freeze up. Use wheel chocks to secure the vehicle from moving.
3. Check all structural fasteners, air system fittings, gaskets, seals and bearings for looseness that can develop due to contraction with cold. Do not over-tighten.
4. Check tire inflation. Tire inflation decreases when the temperature decreases.
5. Periodically check drain holes in the bottom of the relay valve (for trailers with air brakes) and storage compartments. They must be open at all times to avoid moisture entrapment.

Hot Weather Operation

1. Hot weather operation can cause expansion of parts, resulting in tightening of bearings, fasteners, and moving parts. Failure of gaskets or seals can occur.
2. The trailer should be parked in the shade if possible. Long exposure to the sun will shorten service life of rubber components (i.e., tires, light and hose grommets, hoses, etc.) and paint life.
3. Check tire pressure early in the day before beginning operations while the tire is cool. Put all valve stem caps back on after checking.
4. If the area is extremely humid, protect electrical terminals with ignition insulation spray. Coat paint and bare metal surfaces with an appropriate protective sealer.
5. For trailers with air brakes, the use of a filter-lubricator in the towing vehicle's air delivery system is recommended.

Maintenance and Lubrication

General



DANGER

Proceed with extreme caution. Failure to heed notice may cause injury or death to the person and/or damage to product and property.

- **DO NOT** operate the trailer with defective, broken or missing parts.
- **DO NOT** operate if both extension pin locks are not fully engaged into the pin lock sockets.
- **ALWAYS** chock trailer wheels to prevent movement of the trailer.

IMPORTANT

Landoll Company, LLC. Is not responsible for any equipment that is not properly maintained. Troubleshooting, Repairing and Servicing must be performed by a trained technician. Requires complex electrical system troubleshooting and repair. It is highly recommended to contact the Landoll Trailer Service Department at Landoll.com or phone 800-446-5175 / 888-522-3634.

For service and repair parts, simply record the equipment serial and model number from the identification plate and contact the Landoll Trailer Service Department at Landoll.com or phone 800-446-5175 / 888-522-3634. for assistance.

This section contains instructions necessary for proper maintenance of the equipment. This equipment is designed for years of service with minimal maintenance. However, proper maintenance is important for durability and safe operation and is an owner/user responsibility.

A well-planned preventive maintenance & inspection program is important to ensure safe and proper function of the equipment. Determine the cause of the broken, damaged or faulty part and get it repaired immediately.

Landoll Company, LLC. is not responsible for any equipment that is not properly maintained.

The operator has the most responsibility for the overall condition of the equipment. They become the most familiar with the feel, function, performance, sight, smell and sound of the equipment. When findings, faults or symptoms are found, they must effectively communicate this in writing or verbally to the technician for repair.

The technician has the responsibility of correcting the findings, faults or symptoms reported by the operator. To include correcting the findings, faults or symptoms found periodically during the technician inspections and services. The technician also has the responsibility to report any findings, faults, symptoms, causes and corrections to their supervisor.

Cold Weather Tips

Cold weather may cause lubricants to thicken and possible solidify, rubber to harden, and metal to contract.

The moisture attracted by warm parts may condense, collect, and freeze causing immobilized components.

Which may lead to problems found in bearings, electrical systems, and air systems.

1. During any extended stop period, neither the service nor parking brake should be used as they can freeze up. Use wheel chocks to secure the vehicle from moving.
2. Check all structural fasteners, air system fittings, gaskets, seals and bearings for looseness that can develop due to contraction with cold. **DO NOT OVER-TIGHTEN.**
3. Check tire inflation. Tire inflation decreases when the temperature decreases.
4. Periodically check drain holes in the bottom of the relay valve (for trailers with air brakes) and storage compartments. They must be open at all times to avoid moisture entrapment.

Hot Weather Tips

Hot weather may cause lubricants to become extremely thin, rubber to soften, and metal to expand.

Moisture attracted by hot parts may condense, collect, and rust causing immobilized components.

1. Hot weather operation can create certain problems which must be checked. Expansion of parts results in tightening of bearings, fasteners, and moving parts. Failure of gaskets or seals can occur.
2. The trailer should be parked in the shade if possible. Long exposure to the sun will shorten service life of rubber components (i.e. tires, light and hose grommets, hoses, etc.) and paint life.
3. Check tire pressure early in the day before beginning operations while the tire is cool. Replace all valve stem caps after checking.
4. If the area is extremely humid, protect electrical terminals with ignition insulation spray. Clean, prime and paint bare metal surfaces.
5. The use of a filter-lubricator in the tractor's air delivery system is recommended.

Maintenance Schedule

Trailer maintenance includes periodic inspection and lubrication.

See [Trailer Maintenance Schedule on Page 4-7](#) for recommended maintenance and lubrication tasks by time interval and accumulated mileage (use whichever occurs first).

See [Hydraulic Engine Maintenance Schedule \(OPTION\) on Page 4-9](#) for the recommended maintenance tasks for the hydraulic engine package.

Cleaning



WARNING

Proceed with caution. Failure to heed warning may cause injury to person and/or damage product and property.

- **Paint thinner and other solvents are flammable and toxic to eyes, skin, and respiratory tract.**
- **Avoid skin and eye contact.**
- **Good general ventilation is normally adequate.**
- **Keep away from open flames or other combustible items.**

1. Wash trailer to remove all accumulated dirt and grime.
2. Use any mineral spirits paint thinner (or its equivalent) to remove grease and oil from all parts of the trailer. Rinse degreasing solution off with cold water.
 - **DO NOT** use paint thinner to clean any rubber components such as hoses, suspension air bags, and bushings. The paint thinner will dry out the rubber and cause it to deteriorate.
3. Inspect trailer for cause of any reported troubles.
4. Scrape, sand, prime, and repaint areas where finish is missing or where there is evidence of corrosion.
5. Replace any missing or illegible decals. Replace any missing or damaged reflective tape.
6. [See Troubleshooting Guide on Page 5-1](#) for any trailer system not functioning correctly, or where wear, distortion, or breakage can be found. Administer "REMEDY" according to right-hand column of Troubleshooting guide.
7. After disassembling any components, thoroughly clean dirt and old lubricant from all parts.
 - **DO NOT** use a wire brush on any bearing parts or surfaces. Use a natural or synthetic bristle brush.
 - **DO NOT** use compressed air, or spin bearing parts when cleaning. These practices can throw solvents, dirt, or metal particles into your eyes.
 - Dry clean parts with lint free, clean, soft absorbent, cloth or paper. Wash and dry hands.
8. Inspect seals, seal wiping surfaces, bearing caps, and bearing cones for wear, pitting, chipping, or other damage.

Inspection

These inspections look for broken, defective, and leaking components, structural damage, and functionality of the equipment.

Fluid Leak Classification

Fluid is lost and possible contamination in a leaking system and may cause poor function and premature failure within the components.

Leaks may be visible by signs of wetness appearing around components seals, gaskets, fittings, and hose/line connections. Leaking hoses may also show signs of staining that also indicates leakage.

- If any fittings or connections are loose, tighten.
- If any items are broken or defective report it.
- **Any signs of a leaking fuel system or brake system, DO NOT operate and report it to your supervisor or maintenance immediately.**
- **Report any Class 3 leak to your supervisor or maintenance immediately and DO NOT operate.**
- **Class 1 or 2 leaks may be operated but closely monitored and the fluid level checked more frequently.**
- **Report any leak to your supervisor or maintenance.**

Fluid Leak Classifications:

- **Class 1:** Signs of wetness or stains that do not form drops.
- **Class 2:** Signs of drops forming but not dripping.
- **Class 3:** Signs of drops dripping.

Inspection Overview

1. Inspect the trailer, and trailer parts periodically for damage or signs of pending failure, **See Trailer Maintenance Schedule on Page 4-7.**
 - Damaged or broken parts must be repaired or replaced at once.
 - Determine the cause of any binding or hydraulic leakage at once.
 - Correct the problem before using the tractor or trailer.
2. Use the **Troubleshooting Guide on Page 5-1** to check for “SYMPTOMS” and “PROBLEMS” of any trailer system not functioning correctly, or where wear, distortion, or breakage are found. Administer “REMEDY” according to the right-hand column of the troubleshooting section.

Lubrication

During inspections of the trailer, if lubricants are dirty, those parts should be cleaned with paint thinner, dried, and then lubricated immediately.

Dirt in the lubricant forms an abrasive compound that will wear parts rapidly.

Lubrication Points see:

- **Lubrication Points on Page 4-5.**

Lubrication Numbers and Specifications see:

- **Lubricant Specifications on Page 4-6.**

Maintenance Schedule see:

- **Trailer Maintenance Schedule on Page 4-7.**
- **Trailer Maintenance Schedule Notes on Page 4-8.**
- **Hydraulic Engine Maintenance Schedule (OPTION) on Page 4-9.**

Repair Parts

An operator and parts manual come with the trailer and stored in the manual holder tube located on the side of the gooseneck control box from the factory.

- **These manuals do receive updates. Which may be determined by the revision number of the manual.**
 - The revision number is the last four digits of the manual’s part number.
 - Before 1 January 2023, the revision number format was the month/year (example: 0422).
 - After 1 January 2023, the revision number format changed to the year/month (example: 2301).
- **When re-ordering new or updated manuals, DO NOT include the last four digits of the manual, it may be out of date.**
 - Each manual has its own part number and revision, which may be found at the bottom of the pages (example: F-1234-2401).
 - Both manuals are listed on the backside of the front cover at the bottom of the Instructions for Ordering Parts page.
 - The back cover of each manual lists the replacement part number for that specific manual.

These manuals only cover the most common parts and options.

If a particular part or option is needed:

- **Record the equipment VIN/NIV number from the identification plate and contact your locally authorized Landoll Dealer.**

The operator’s manual covers the operation,

troubleshooting, maintenance procedures and torque limits needed during equipment service and repairs.

It also lists additional manufacturer references to assist in the troubleshooting, servicing, and repairing of outsourced components applied to the equipment at the factory.

Manufacturer references are also available through your locally authorized Landoll Dealer.

The parts manual displays mechanical, air, electrical, hydraulic components (with part numbers), and schematical diagrams.

It is highly recommended that all service and repair parts are acquired through an authorized Landoll Dealer.

- Simply record the equipment VIN/NIV number from the identification plate, build the parts list, and contact a dealer near you.
- To find that dealer, please visit landoll.com, or call 1-800-423-4320 for assistance.

Dealers Only: Parts, Trailer Manuals, and Manufacturer References are available online through the Dealer Portal at dealer.landoll.com.

Structural Defects

If any structural defect is found, the fault must be corrected before further use of the vehicle.

Continued usage could endanger the trailer, its load, personnel, traffic, and properties.

If any cracks or breaks are found, contact the Landoll factory for repairs. Inspect the deck daily for broken or missing planks or missing attachments.

Replace any defective parts promptly.

Wood Deck Care

Sunlight, weather, and the loads being hauled will damage the wooden deck and surface sealer.

Applying a good water sealer that contains a UV inhibitor to all visible surfaces of the deck wood will help protect the wood. Using a hand held roller or hand held pump sprayer, apply every 6 months (recommend spring and fall).

More frequent applications may be required due to environmental conditions and load damage.

Tools and Equipment

Tools, equipment, and personnel normally found in a facility capable of making truck repairs will be adequate for maintenance of the trailer. No other special tools or equipment should be necessary.

Torque Values

See [Specific Bolt Torques on Page 2-2](#) or [General Torque Specifications on Page 2-3](#) for standard hardware and hydraulic fittings. They are intended as a guide for average applications involving typical stresses and mechanical surfaces. Values are based on the physical limitations of clean, plated, and lubricated hardware. In all cases, when an individual torque value is specified, it takes priority over values given in this table. Replace original fasteners with hardware of equal grade.

Lubrication & Maintenance Schedule

Lubrication Points

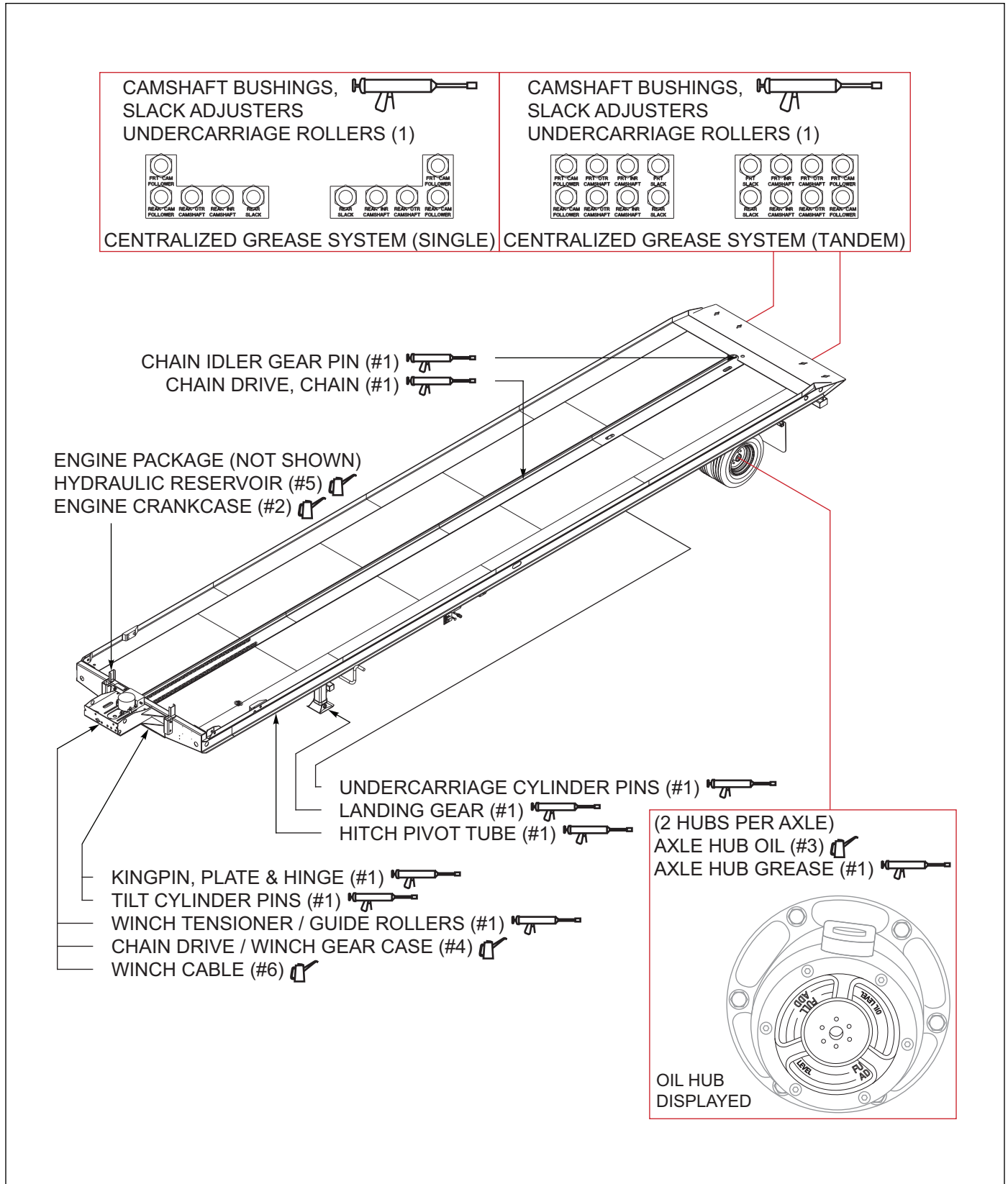

Figure 4-1: Lubrication Points

Lubricant Specifications

EXPECTED TEMPERATURES

ABOVE 15° F (-9° C)	BELOW 15° F (-9° C)
---------------------	---------------------

LUBE #	LUBRICATION	CAPACITIES	EXPECTED TEMPERATURES	
			ABOVE 15° F (-9° C)	BELOW 15° F (-9° C)
1	GREASE, MULTI PURPOSE	N/A	LITHIUM MULTI -PURPOSE EP2 NLGI 2	LITHIUM MULTI -PURPOSE EP2 NLGI 2
2	OIL, ENGINE	CRANKCASE (ENGINE OPTION) (1.7 - 2 QT) (1.6-1.9 L)	SAE 10W-30	SAE 5W-20 / 5W-30
3	OIL, GEAR	AXLE HUBS	SAE 80W-90	SAE 80W-90
4	OIL, GEAR	WINCH / CHAIN DRIVE GEAR CASE (OPTION)	SAE 85W-140	SAE 75W-90
5	OIL, HYDRAULIC	RESEVOIR ENGINE PACK OPTION (30 GAL) (113 L) WET KIT OPTION (35 GAL) (132 L)	ISO GRADE 32	ISO GRADE 32
6	OIL, MULTI PURPOSE	WINCH CABLE (OPTION)	RUST & OXIDATION PROHIBITING ISO 32	RUST & OXIDATION PROHIBITING ISO 32
7	OIL, AIR TOOL	AIR LUBRICATING SYSTEM	AIR TOOL OIL, STANDARD GRADE	AIR TOOL OIL, WINTER GRADE

Table provided for general use.

NOTES:

Trailer Maintenance Schedule

KEY	C-Clean, I-Inspect, L-Lubricate, R-Replace, T-Tighten/Adjust Torque						
ITEM	1st 5 Hours or 50 Miles (80 Km)	Weekly or 500 Miles (805 Km)	Monthly or 2,000 Miles (3219 Km)	6 Months or 12,000 Miles (19,312 Km)	Yearly or 25,000 Miles (40,234 Km)	LUBE #	NOTES
LIGHTS	I	I					A
WIRING & CONNECTIONS	I		I				A
FASTENERS	I,T		I,T		I,T		A,B
KINGPIN, PLATE, HINGE & PIVOT TUBE	I		C,I,L			1	A,C
GOOSENECK TILT CYLINDER PINS	I		C,I,L			1	A,C
LANDING GEAR	I		C,I,L			1	A,C
AIR TANKS DRAINED	DAILY						A
AIR SYSTEM FILTER & LUBRICATOR (OPTION)		I, L	I,R (EVERY 3 MONTHS)	I,R	I,R	7	A,J
AIR SYSTEM BRAKE PROTECTION VALVE FILTERS		I	I,R (EVERY 3 MONTHS)	I,R	I,R		A,J
BRAKE AIR SYSTEM	I	I	I				A
RELAY VALVES					I,C		A
BRAKE ADJ & WEAR	I		I,T				A,D
CENTRALIZED GREASE SYSTEM SLACK ADJUSTERS CAMSHAFT BUSHINGS UNDERCARRIAGE ROLLERS	I	I,L				1	A,C
NYLATRON HOLD-DOWN AND GLIDE WEAR STRIPS	I		I	C,I		1	A,G
AXLE HUB OIL (STANDARD)	I	I,L			C,I,R	3	A,C
WHEEL BEARINGS, OIL	I				C,I,T		A,B,F
AXLE HUB GREASE (OPTION)	I	I		C,I,L		1	A,C
WHEEL BEARINGS, GREASE	I			C,I,T			A,B,F
TIRE INFLATION & WEAR	I	I					A,E
WHEEL LUG NUTS	I,T	I	I,T				A,B
SUSPENSION ALIGNMENT & FASTENERS	I		I	I,T	I,T		A,B
AIR RIDE SUSPENSION			I,T		I,T		A
UNDERCARRIAGE TRAVEL CYLINDER PINS	I		C,I,L			1	A,C
HYDRAULIC OIL <i>(Fill as needed)</i>	I	I			R	5	A,C
HYDRAULIC FILTER	R			R			A
HOSES <i>(Replace as needed)</i>	I		I		I		A
ENGINE (OPTION)						2	A,C,H,I
WINCH , CABLE (OPTION)	I		I,L			6	A,C,H,I
WINCH , TENSIONER / GUIDE / DECK ROLLERS (OPTION)	I		I,L			1	A,C,H
WINCH , GEAR CASE (OPTION) <i>(Fill as needed)</i>	I		I			4	A,C,H,I
CHAIN DRIVE , CHAIN (OPTION)	I		I,L			1	A,C,H
CHAIN DRIVE , IDLER GEAR PIN (OPTION)	I		I,L			1	A,C,H

Trailer Maintenance Schedule							
KEY	C-Clean, I-Inspect, L-Lubricate, R-Replace, T-Tighten/Adjust Torque						
ITEM	1st 5 Hours or 50 Miles (80 Km)	Weekly or 500 Miles (805 Km)	Monthly or 2,000 Miles (3219 Km)	6 Months or 12,000 Miles (19,312 Km)	Yearly or 25,000 Miles (40,234 Km)	LUBE #	NOTES
CHAIN DRIVE, GEAR CASE (OPTION) (Fill as needed)	I		I			4	A,C,H

Trailer Maintenance Schedule Notes

- NOTES:**
- A. Perform at the time shown. Shorten service intervals when operating in severe or dirty conditions.
 - B. See torque specifications on [Pages 2-2 to Page 2-4](#).
 - C. See recommended lubricant on [Page 4-6](#).
 - D. See Brake System Maintenance Procedures on [Page 4-20](#).
 - E. For Tire Pressures, see Serial Number Plate on the front of the semitrailer.
 - F. See Wheel Bearing Lubrication and Adjustment Procedures on [Page 4-27](#).
 - G. Nylatron Hold-Down and Glide Wear Strips are self lubricating. If chatter or squealing occurs lightly apply grease.
 - H. Inspect prior to and after each use.
 - I. See Engine Maintenance Schedule on [Page 4-9](#). For Engine / Winch Operation and Maintenance procedures resource the Engine / Winch Manufactures References. Parts are available through an authorized Landoll Dealer.
 - J. Replace every 3 months, unless air flow has been substantially reduced.

Table provided for general use.

NOTES:



DANGER

Breathing exhaust gases can result in severe personal injury or death. Do not use air cleaner, exhaust elbow, or connecting parts as a supporting step. Damage to these and connecting parts can cause an exhaust leak.

Hydraulic Engine Maintenance Schedule (OPTION)

KEY	C-Clean, I-Inspect, L-Lubricate, R-Replace, T-Tighten/Adjust Torque					
	ITEM	Daily	Weekly or 25 Hours	Yearly or 100 Hours	150 Hours	200 Hours
ENGINE OIL LEVEL (Fill as needed, DO NOT OVERFILL)	I		*R			
FUEL LEVEL (Fill as needed)	I					
FUEL SYSTEM COMPONENTS (Replace items as needed)	I					
COOLING SYSTEM / AREA (Clear obstructions)	*I,C		*I,C			
AIR CLEANER HOUSING & COMPONENTS, SHROUDS, EQUIPMENT COVERS AND GUARDS	*I,C,T		*I,C			
SPARK ARRESTOR (If equipped)	I					
AIR FILTER & PRECLEANER OR INNER ELEMENT		*I,C	*R			
OIL COOLER FINS (If equipped)			*I,C			
HEAVY DUTY FILTER MINDER (If equipped)				I		
FUEL FILTER					*R	
OIL FILTER					*R	
SPARK PLUGS						*R
CRANKSHAFT SPLINE LUBED (Performed by an Authorized Dealer Only)						*L

NOTES:

*PERFORM THESE MAINTENANCE PROCEDURES MORE FREQUENTLY UNDER EXTREMELY DUSTY, DIRTY CONDITIONS. For Operation and Maintenance procedures resource the Manufactures References. Parts are available through an authorized Landoll Dealer.

Table provided for general use.

NOTES:

Air System Maintenance

Air System Maintenance Schedule

See **Parts Manual** for mechanical, air, electrical and hydraulic components and diagrams.

1. The air tanks must be completely drained daily.
 - Moisture in the system causes rust and corrosion to build inside the components and may lead to system failure.
2. Inspect the air system weekly.
 - If the air system lubricator option is installed, check and refill weekly.
3. Check the brake protection valve filters every 3 months or when the air flow becomes restricted, See **Figure 4-2**.
 - The filters may be cleaned or replaced.

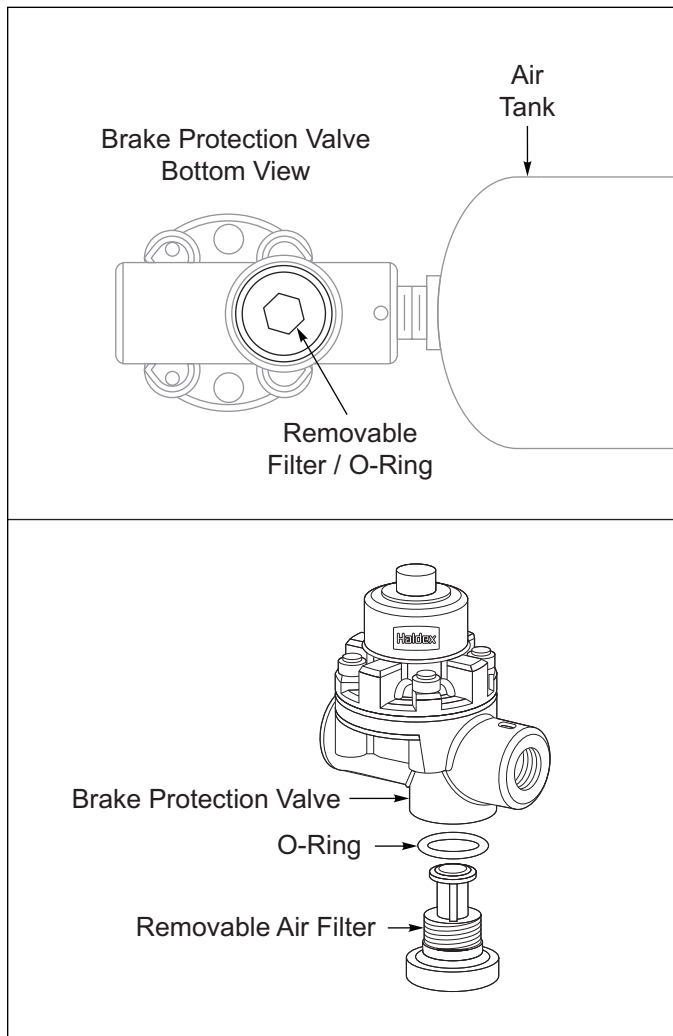

Figure 4-2: Brake Protection Valve Filter

Hydraulic Maintenance



DANGER

Proceed with caution. Failure to heed warning may cause injury to person and/or damage to product and property.

- **DO NOT** operate if the fuel system or brake system is leaking. Report it immediately to your supervisor or maintenance.
- **ALWAYS** report any Class 3 leak to your supervisor or maintenance immediately.

Tractor must be equipped with a relief valve set at a maximum 2500 psi (17,237 kpa).

This trailer requires hydraulic power to operate, supplied by either the tractor or a trailer mounted hydraulic power pack.

Maintenance of the hydraulic system consists of inspection and minor servicing.

Fluid is lost and possible contamination in a leaking system and may cause poor function and premature failure within the components.

Fluid Leak Classification

- Any signs of a leaking fuel system or brake system, **DO NOT** operate and report it to your supervisor or maintenance immediately.
- Report any Class 3 leak to your supervisor or maintenance immediately and **DO NOT** operate.
- Class 1 or 2 leaks may be operated but closely monitored and the fluid level checked more frequently.
- Report any leak to your supervisor or maintenance.

Leaks may be visible by signs of wetness appearing around components seals, gaskets, fittings, and hose/line connections. Leaking hoses may also show signs of staining that also indicates leakage.

- If any fittings or connections are loose, tighten.
- If any items are broken or defective report it.

Fluid Leak Classifications

- **Class 1:** Signs of wetness or stains that do not form drops.
- **Class 2:** Signs of drops forming but not dripping.
- **Class 3:** Signs of drops dripping.

Hydraulic Maintenance Schedule

See **Parts Manual** for mechanical, air, electrical and hydraulic components and diagrams.

1. The hydraulic fluid level in the reservoir must be checked weekly, **See Trailer Maintenance Schedule on Page 4-7.**
- **Unless a leak/leaks develop, classify it, report it and monitor it more frequently.**
 - a. Retract all hydraulic cylinders.
 - b. Hydraulic pump shut off.
 - c. Operate the hydraulic control levers to release any line pressure back to the reservoir.
 - d. Check fluid level in the reservoir. **DO NOT** overfill the reservoir, allow for fluid heat expansion.
 - e. Use only recommended hydraulic fluid, **See Lubricant Specifications on Page 4-6.**
2. Inspect the hydraulic system weekly.
 - a. Start the hydraulic pump
 - b. Operate each hydraulic control lever and observe for any leaks and the functionality of the system.
 - c. Place the trailer back into travel position.
 - d. Shut off the hydraulic pump.
3. Change hydraulic filter every 6 months or 12,000 miles, whichever ever comes first, **See Trailer Maintenance Schedule on Page 4-7.**
 - Under adverse conditions, change more frequently.

Hydraulic Engine Package

1. Check the hydraulic oil level weekly, or after any leakage. **See See Lubricant Specifications on Page 4-6** for proper hydraulic oil. Check oil level with hydraulic cylinders in the retracted position and with the engine stopped., **See Hydraulic Engine Maintenance Schedule (OPTION) on Page 4-9.**
2. Check hoses weekly for cracks or leaks. If a valve or line leaks, it should be replaced immediately.
3. Check the engine oil each time before using. Oil level should be maintained between the “**ADD**” and “**FULL**” marks on the oil dip stick.
4. Replace hydraulic filter with new filter at least *every 6 months* or more often under adverse conditions.
5. Use the fuel recommended for the engine package installed on your semitrailer.
6. For further maintenance procedures and proper lubrication specifications, please refer to the engine owners manual that was supplied with the hydraulic engine package.

Electrical System

1. Maintenance of the electrical system consists of inspection and minor servicing. Any wire, connection or electrical component showing signs of corrosion, wear, breakage or unraveling must be repaired or replaced.
2. Frayed or unraveling wire must have the defective section removed and replaced with wire of the same color and gauge. Seal all connections and insulate.
3. Corroded terminals must have the corrosion removed, source of corrosion neutralized and the terminals resealed, protected, and insulated.
4. Fuse or circuit breaker burn-out or blow-out usually indicates an electrical short-circuit, although a fuse can occasionally fail from vibration. Insert a second fuse or reset the breaker. If this fuse immediately burns out or the breaker trips, locate the cause of the electrical short and repair.
5. A light that repeatedly burns-out usually indicates a loose connection, poor system ground, or a malfunctioning voltage regulator. Locate the source of the problem and repair. System grounds must be grounded to bare metal surfaces. Paint, grease, wax, and other coatings act as insulators. Replacement lamps must be equivalent to the factory installed lamp.

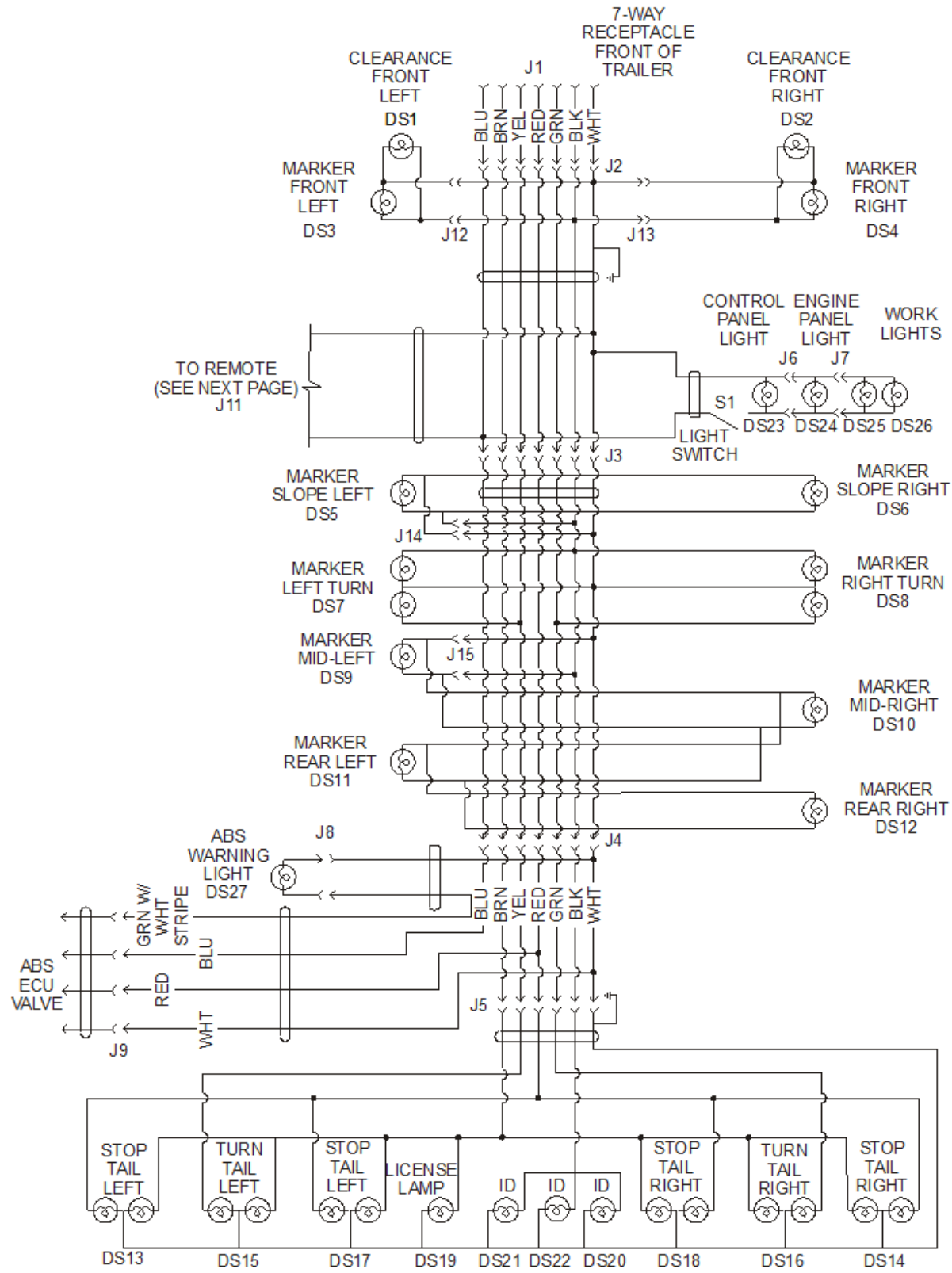

m143208 elect op - 330c

Figure 4-3: 330D Container Wiring Diagram

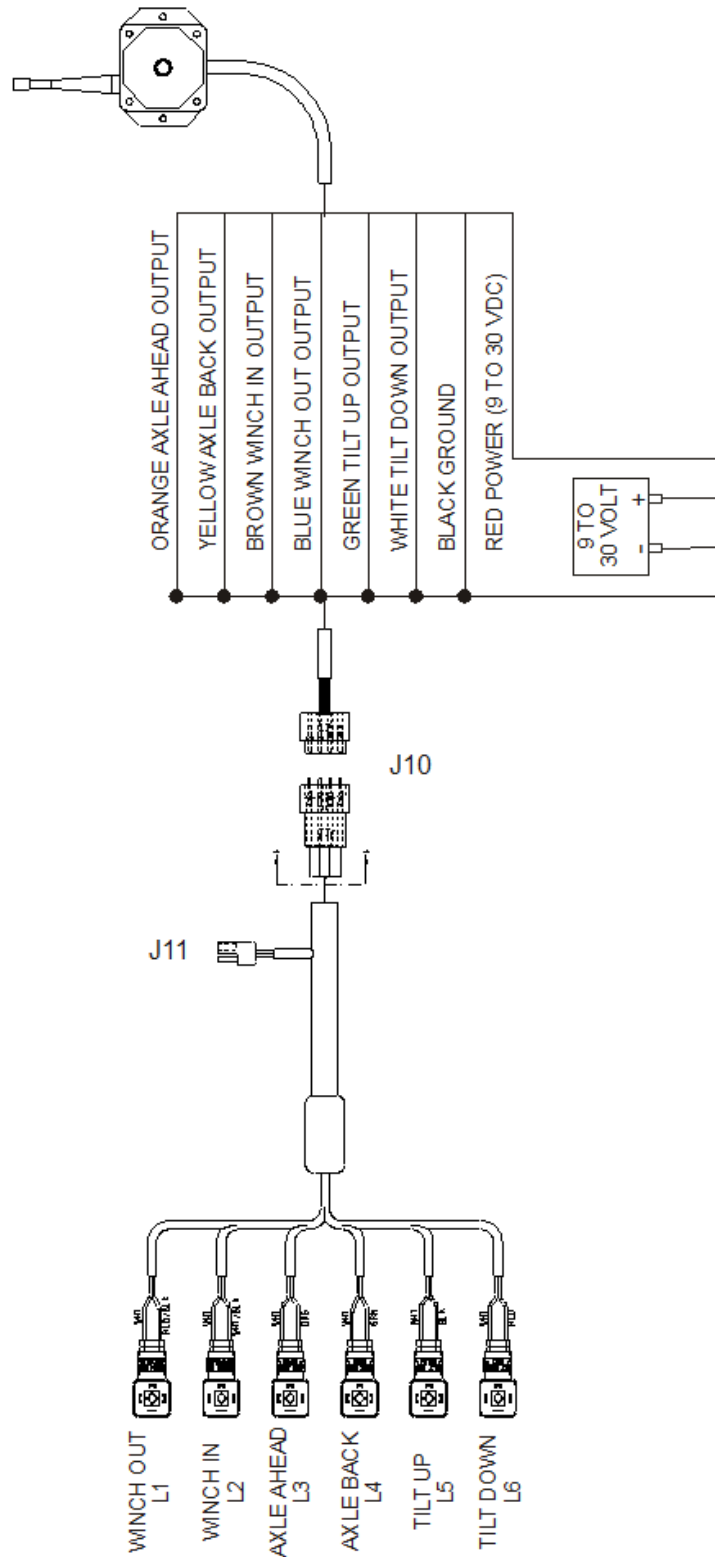

330 remote control schematic

Figure 4-4: Remote Wiring Diagram

330D CONTAINER WIRING PARTS LIST			
REF. DES.	FUNCTION	REF. DES.	FUNCTION
DS1	FRONT LEFT CLEARANCE, YELLOW	J1	7 WAY RECEPTACLE
DS2	FRONT RIGHT CLEARANCE, YELLOW	J2	FRONT MAIN CONNECTOR
DS3	FRONT LEFT MARKER, YELLOW	J3	BED MAIN CONNECTOR
DS4	FRONT RIGHT MARKER, YELLOW	J4	E-CHAIN CONNECTOR
DS5	LEFT SLOPE MARKER, YELLOW	J5	BUMPER CONNECTOR
DS6	RIGHT SLOPE MARKER, YELLOW	J6	ENGINE PANEL LIGHT
DS7	LEFT SIDE MARKER/TURN, YELLOW	J7	WORK LIGHTS
DS8	RIGHT SIDE MARKER/TURN, YELLOW	J8	ABS LAMP CONNECTOR
DS9	MID-LEFT SIDE MARKER, YELLOW	J9	ABS ECU VALVE CONNECTOR
DS10	MID-RIGHT SIDE MARKER, YELLOW	J10	REMOTE RECEIVER CONNECTOR
DS11	LEFT REAR SIDE MARKER, RED	J11	REMOTE CONNECTOR
DS12	RIGHT REAR SIDE MARKER, RED	J12	FRONT CORNER MARKER, LEFT CONNECTOR
DS13	LEFT STOP/TAIL, RED	J13	FRONT CORNER MARKER, RIGHT CONNECTOR
DS14	RIGHT STOP/TAIL, RED	J14	FRONT BED MARKER CONNECTOR
DS15	LEFT TURN/TAIL, RED	J15	REAR BED MARKER CONNECTOR
DS16	RIGHT TURN/TAIL, RED	L1	AXLE LOAD
DS17	LEFT STOP/TAIL, RED	L2	AXLE TRANSPORT
DS18	RIGHT STOP/TAIL, RED	L3	WINCH IN
DS19	LICENSE PLATE LIGHT, RED	L4	WINCH OUT
DS20	IDENTIFICATION RIGHT, RED	L5	TILT UP
DS21	IDENTIFICATION LEFT, RED	L6	TILT DOWN
DS22	IDENTIFICATION CENTER, RED	L7	WORK LIGHT
DS23	CONTROL PANEL		
DS24	ENGINE PANEL		
DS25	WORK LIGHT		
DS26	WORK LIGHT		
DS27	ABS MALFUNCTION INDICATOR, YELLOW		

Table 4-1: Wiring Parts List

Suspension Maintenance

Spring Suspension

1. Make certain that all springs are properly located on the wear pads. Twisted springs or cocked hangers will cause uneven spring contact with wear pad and will result in excessive wear on the spring suspension. Check the shocks for excessive wear.

2. Replacing the equalizer bushings and the torque arm bushings on the spring suspension is a complex operation and should be left to trained service personnel. If the bushings need to be replaced contact a Landoll authorized service center or the Landoll factory for servicing.

Air Ride Suspension

1. Physically check all nuts, bolts, and air line fittings for proper torque **See Specific Bolt Torques on Page 2-2.**
2. Check all other suspension components for any sign of damage, looseness, wear or cracks.
3. With trailer on level surface and air pressure in excess of 65 psi, all air springs should be of equal firmness. The height control valve on right side of the axle controls all air springs on tandem axle suspensions.

Air Ride Height Adjustment



WARNING

1. Not following proper installation and adjustment procedures can result in broken shock absorbers, burst air bags and/or over height problems. This potentially hazardous situation could result in death or serious injury.
2. **DO NOT** adjust by loosening the 1/4 inch Adjusting Lock Nut and Bolt. This procedure may cause damage to the valve and require replacement. Contact Landoll Service Department for detailed instructions on Suspension Ride Height Adjustment.

IMPORTANT

This manual does not cover the suspension ride height installation or adjustment procedures, due to the setup steps variation of the different trailers frames. For proper ride height installation and adjustment, simply record the equipment VIN/NIV number from the identification plate and contact the Landoll Trailer Service Department. Please visit <https://landoll.com/contact-us/service-contacts/land-oll-trailer-service/> or call 1-800-446-5175 for

NOTE

See Parts Manual for mechanical, air, electrical and hydraulic components and diagrams.

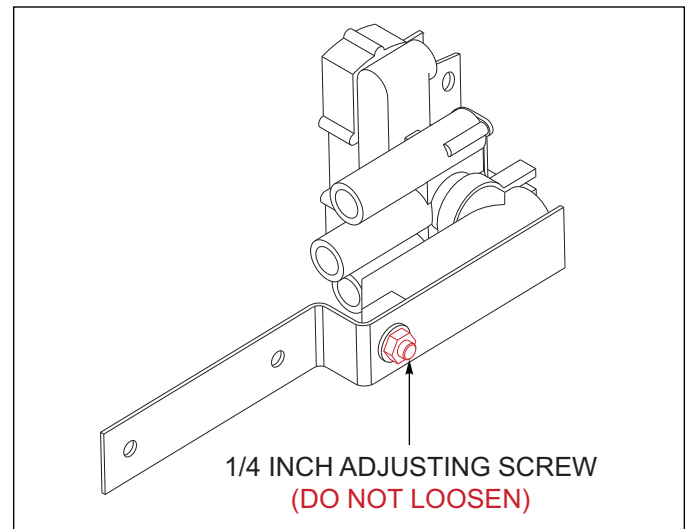

Figure 4-5: Height Control Valve

Alignment

Wheel Alignment



DANGER

To prevent a life threatening accident:

1. Support trailer and undercarriage so tires are off the ground.
2. Support the trailer and undercarriage on jack stands with sufficient capacity to support the total weight of the trailer and any load which it may be carrying.

When trailer tires show signs of scuffing, feather-edging or uneven wear, examine the trailer for damaged suspension (frame, shocks, linkage, etc.), axle, wheel bearings and wheels. Proper wheel alignment and wheel bearing adjustment is essential for proper tire wear. The simplest form of checking wheel alignment “toe” is by running the trailer over a “SCUFF GAUGE”. A scuff gauge reading of 16 feet or less per mile is considered satisfactory. If a scuff gauge is not readily available, or edge wear on one side of a tire is occurring signifying positive or negative camber, alignment can be checked as follows:

1. Remove wheel, hub and bearing assemblies.
2. Place a 3-point axle gauge against the front side of the axle, and adjust each axle gauge point to the axle. (Double point end against the inner and outer wheel bearing surfaces of the spindle being checked and the other point on the inner bearing surface on the other spindle.)(See Figure 4-7.)

3. Move the axle gauge and place against the back side of the axle. If either of the points of double point end fails to touch the axle surface, a bent spindle is evident. A point gap of .015" or more is considered excessive tire "toe" and the axle must be replaced (See Figure 4-9.)
4. Follow the same procedures as in **Steps 2 and 3**, except place the axle gauge above and below the axle. If gauge point gap is found, the axle has positive or negative camber. The trailer axle has no camber from the factory. If it is found to have positive or negative camber, axle replacement is necessary (See Figure 4-6 for examples of camber).

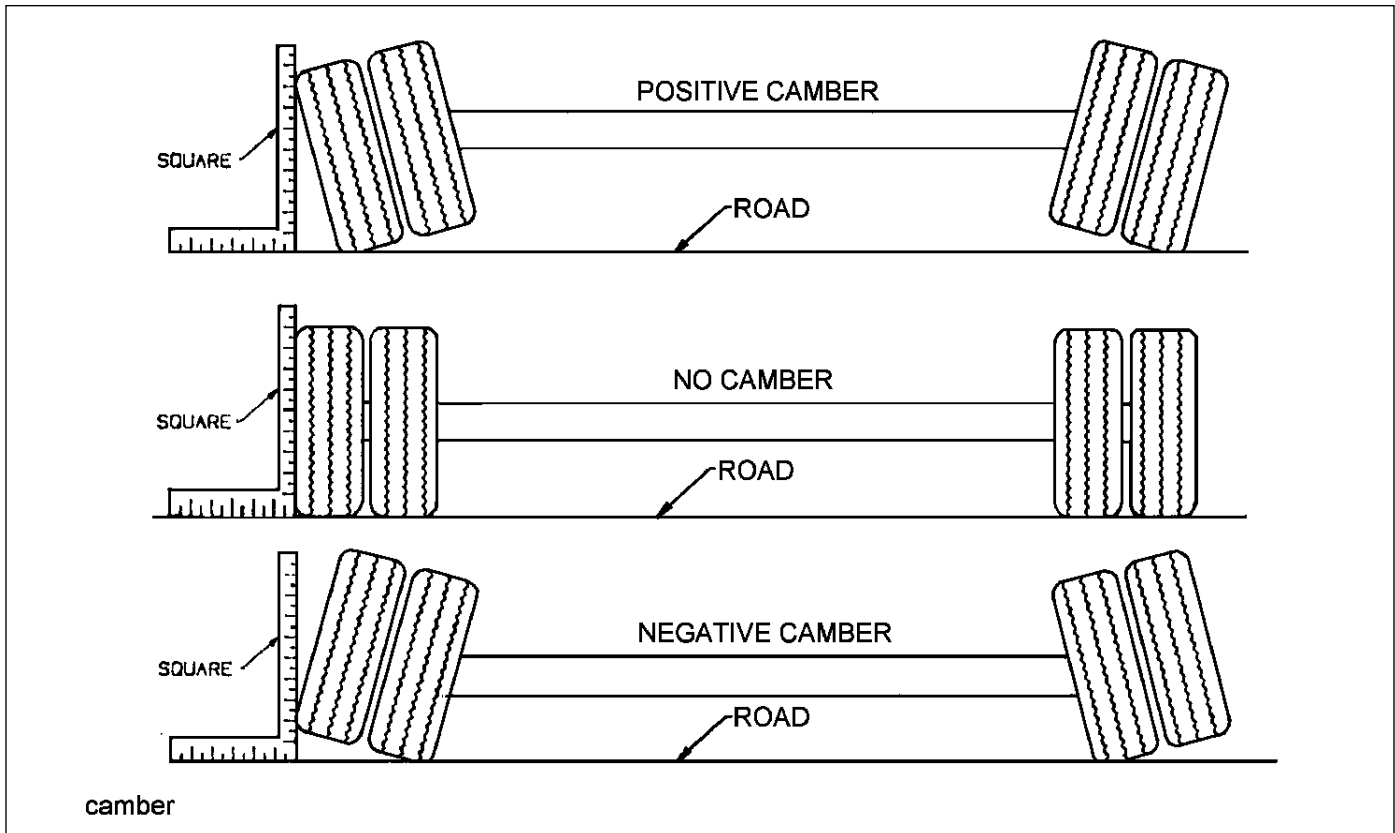

Figure 4-6: Examples of Camber

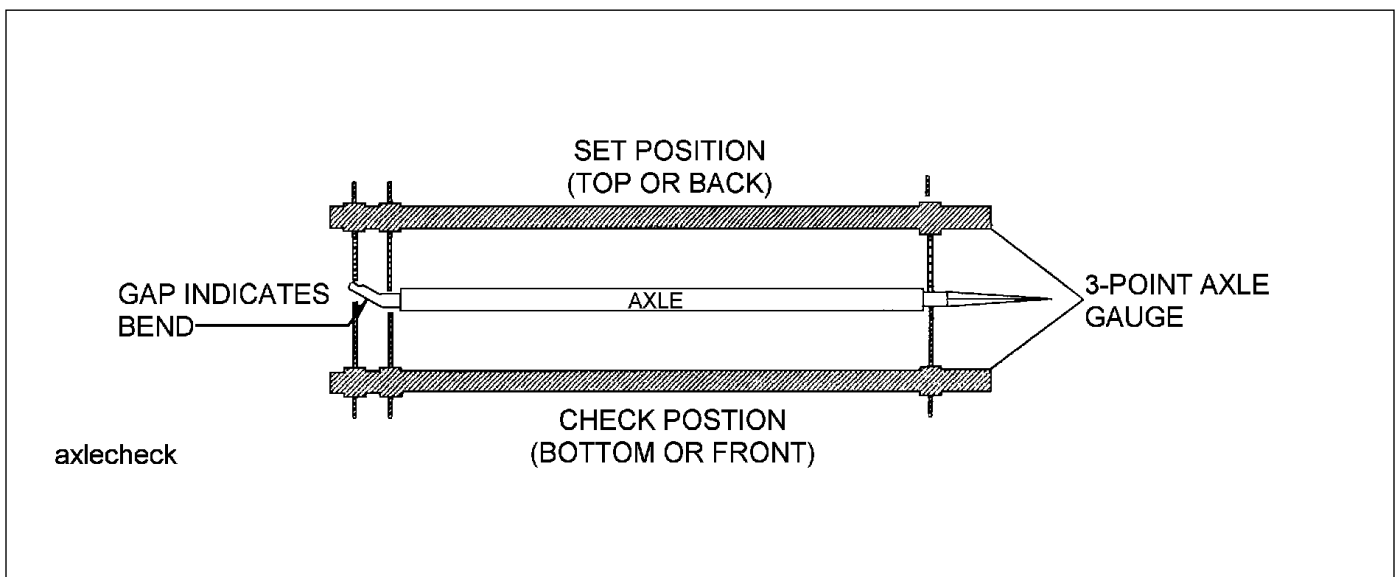

Figure 4-7: Checking Axle for Bend

Axle Alignment

Air Ride Alignment, [Page 4-17](#).

Spring Ride Alignment, [Page 4-19](#).

Alignment, Air Ride Trailer 1st Axle Procedure

IMPORTANT

Proper axle-to-kingpin alignment is necessary to obtain straight tracking. If axle alignment is off, “dog-tracking” occurs. “Dog tracking” means the rear of the vehicle will angle, appearing to travel sideways, with its rear end off to one side.

Check alignment manually or by using a trailer alignment machine. In either case, a thorough inspection of the complete suspension must be performed and all defects corrected before aligning.

IMPORTANT

It is highly recommended to contact an authorized Landoll Service Center for servicing and repair.

The air ride suspension is aligned at the factory and should not need re-alignment, until suspension maintenance requires it.

1. Position trailer on a firm and level surface. Eliminate any suspension binding or restrictions due to sharp turns or unusual maneuvers. Make sure that the undercarriage is in the rear most position.
2. Uncouple the tractor from the trailer. If needed, jack up the front of the trailer to allow measurement under the trailer.
3. Inspect the suspension for serviceability. Replace parts as required before aligning.
4. Suspend a plumb bob from the center of the kingpin and set at axle center height.
5. Measure **Curbside (D)** from the plumb bob to the 1st axle center. Measure **Streetside (D1)** from the plumb bob to the 1st axle center. **Curbside (D)** should be about 1/8 in (3.18 mm) shorter than **Streetside (D1)**, [See Figure 4-9](#).
6. **Align if measurement requires:**
 - a. 1-1/8 in Pivot Bolts - Loosen pivot bolt lock nuts and rotate eccentric pivot bolts clockwise or counter-clockwise to adjust. Repeat Steps 5-6 until measurement is achieved, [See Figure 4-8](#).
 - b. 7/8 in Pivot Bolts - Break welds if present between hanger mounts/eccentric collars and pivot lock nuts/jam nuts. Loosen jam nuts if installed. Loosen lock nuts. Rotate eccentric pivot bolts clockwise or counter-clockwise to adjust. Repeat Steps 5 through 6 until measurement is achieved, [See Figure 4-8](#).

7. Tighten and torque suspension pivot bolts and lock nuts, [See Specific Bolt Torques on Page 2-2](#).
8. 7/8 in Pivot Bolts ONLY - Install new jam nuts if damaged or not present. Tighten and torque jam nuts to 150 ft-lbs (205Nm), [See Specific Bolt Torques on Page 2-2](#).

IMPORTANT

DO NOT tack weld Dexter suspension pivoting hardware.

9. SAF-Holland Only: Tack weld the inner nuts to the eccentric alignment blocks.

Alignment, Air Ride Trailer 2nd & 3rd Axle Procedure

It is highly recommended to contact an authorized Landoll Service Center for servicing and repair.

The air ride suspension is aligned at the factory and should not need re-alignment, until suspension maintenance requires.

1. Align the 1st axle using the method outlined in [Alignment, Air Ride Trailer 1st Axle Procedure](#).
2. Measure from 1st axle center to the trailer 2nd axle center on the curbside then the streetside. Measurements should be the same. Use **(Y)** and **(Y1)** as reference, [See Figure 4-9](#).
3. **Align if measurement require:**
 - a. 1-1/8 in Pivot Bolts - Loosen pivot bolt lock nuts and rotate eccentric pivot bolts clockwise or counterclockwise to adjust. Repeat Steps 5 through 6 until measurement is achieved, [See Figure 4-8](#).
 - b. 7/8 in Pivot Bolts - Break welds if present between hanger mounts/eccentric collars and pivot lock nuts/jam nuts. Loosen jam nuts if installed. Loosen lock nuts. Rotate eccentric pivot bolts clockwise or counterclockwise to adjust. Repeat Steps 5 through 6 until measurement is achieved, [See Figure 4-8](#).
4. Tighten and torque suspension pivot bolts and lock nuts, [See Specific Bolt Torques on Page 2-2](#).
5. 7/8 in Pivot Bolts ONLY - Install new jam nuts if damaged or not present. Tighten and torque jam nuts to 150 ft-lbs (205Nm), [See Specific Bolt Torques on Page 2-2](#).

DO NOT tack weld Dexter suspension pivoting hardware.

6. SAF-Holland Only: Tack weld the inner nuts to the eccentric alignment blocks.

7. If additional trailer axles are available, use the same procedures performed on the previous axle aligned and repeat steps 2 through 6.

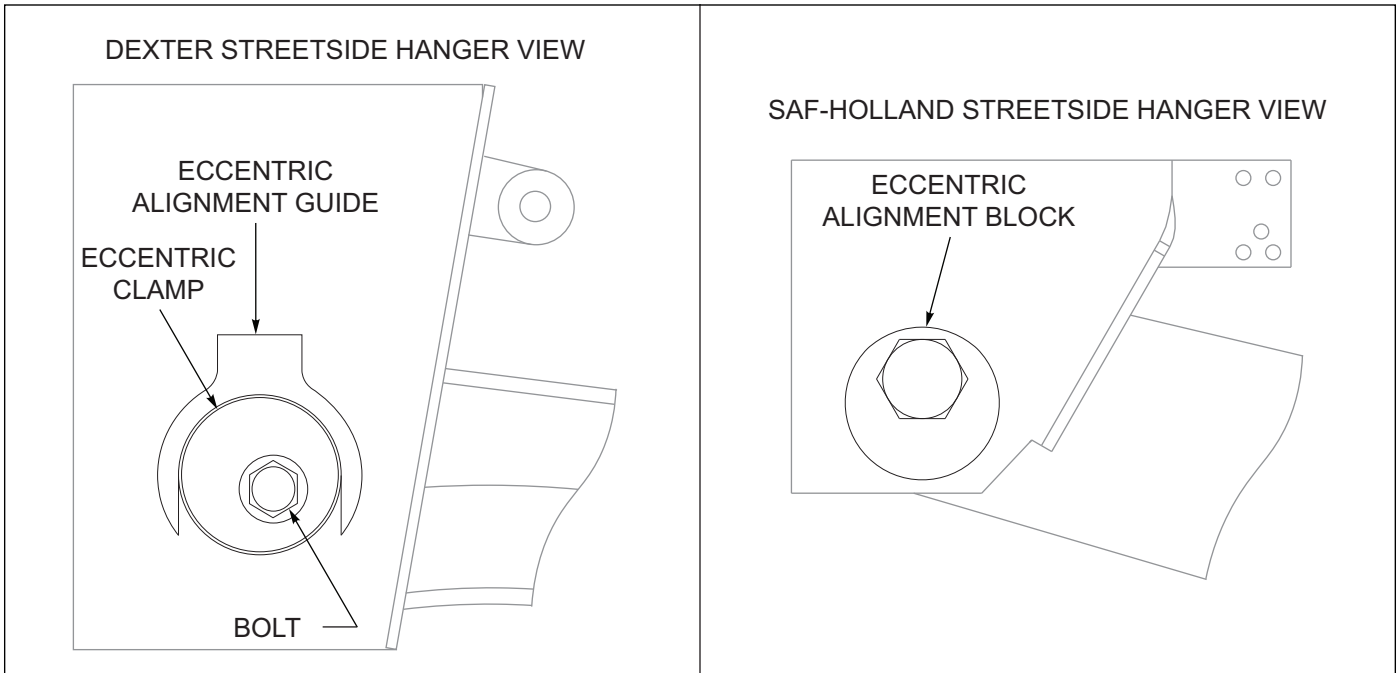

Figure 4-8: Streetside Suspension Hanger

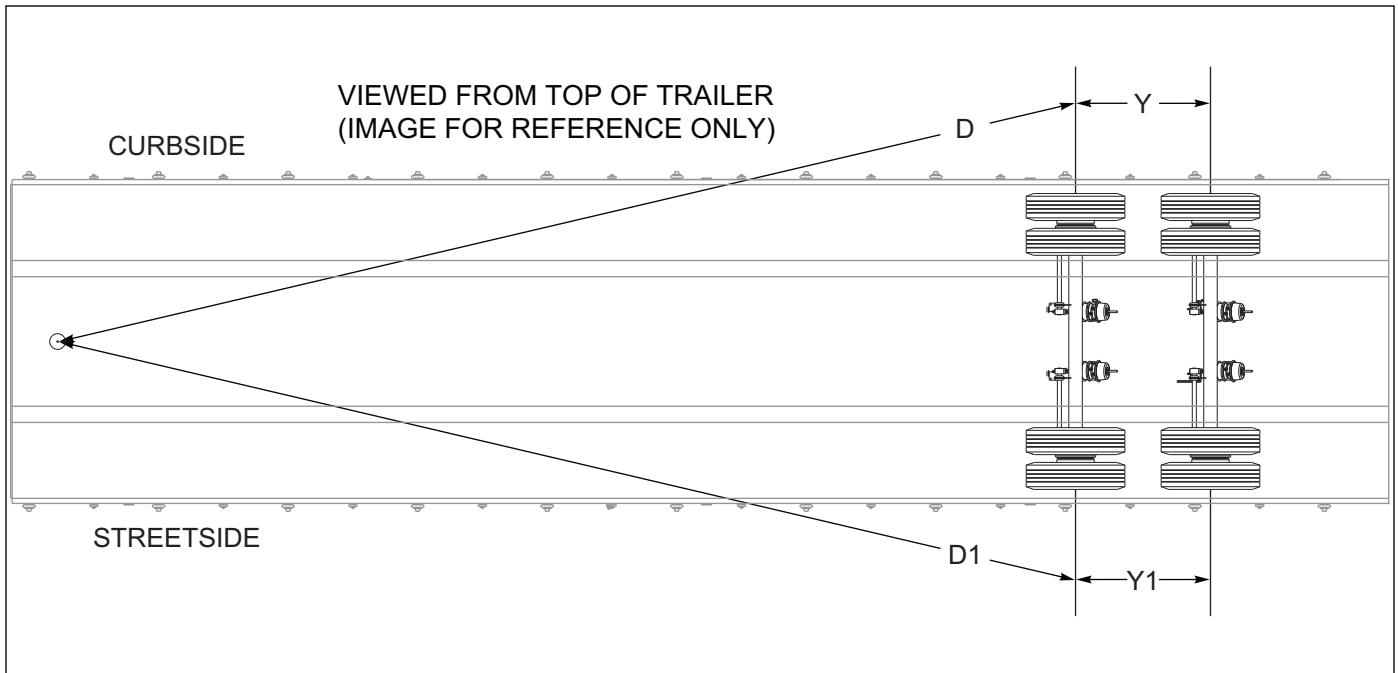

Figure 4-9: Checking Axle Alignment

Alignment, Spring Ride Trailer 1st Axle Procedure

IMPORTANT

Proper axle to kingpin alignment is necessary to obtain straight tracking. If axle alignment is off, “dog-tracking” occurs. Check alignment manually or by using a semitrailer alignment machine. In either case, a thorough inspection of the complete suspension must be performed and all defects corrected before aligning.

The air ride suspension is aligned at the factory and should not need re-alignment, until suspension maintenance requires.

1. Position semitrailer on a firm and level surface. Eliminate any suspension binding or restrictions due to sharp turns or unusual maneuvers. **ENSURE** that the undercarriage is in the rear most position.
2. Uncouple the tractor from the trailer. If needed jack up the front of the trailer to allow measurement under the trailer.
3. Inspect the suspension for serviceability. Replace any defective part before aligning.
4. Suspend a plumb bob from the center of the kingpin and set at axle center height.
5. Measure **Curbside (D)** from the plumb bob to the 1st axle center. Measure **Streetside (D1)** from the plumb bob to the 1st axle center. **Curbside (D)** should be about 1/8 inch (3.175 mm) shorter than **Streetside (D1)**. See Figure 4-9.
6. Align if measurement requires: Loosen the adjustable torque arm clamp bolts. Slightly loosen the axle u-bolt sets evenly on each side of the axle, See Figure 4-10.

7. Turn the adjustable torque arm clockwise or counter-clockwise to adjust. Repeat Steps 5-7 until measurement is achieved. See Figure 4-10.
8. Tighten and torque the adjustable torque arm nuts. See Specific Bolt Torques on Page 2-2.
9. Re-adjust the u-bolts to be square on the axle. Evenly tighten and torque u-bolt nuts. See Specific Bolt Torques on Page 2-2.

Alignment, Spring Ride Trailer 2nd & 3rd Axle Procedure

The spring ride suspension is aligned at the factory and should not need re-alignment, until suspension maintenance requires.

1. Align the 1st axle using the method outlined in [Alignment, Spring Ride Trailer 1st Axle Procedure](#).
2. Measure from 1st axle center to the trailer 2nd axle center on the curbside then the streetside. Measurements should be the same. Use (Y) and (Y1) as reference. See Figure 4-9.
3. Align if measurement requires: Loosen the adjustable torque arm clamp bolts. Slightly loosen the axle u-bolt sets evenly on each side of the axle, See Figure 4-10.
4. Turn the adjustable torque arm clockwise or counter-clockwise to adjust. Repeat Steps 5-7 until measurement is achieved. See Figure 4-10.
5. Tighten and torque the adjustable torque arm nuts. See Specific Bolt Torques on Page 2-2.
6. Re-adjust the u-bolts to be square on the axle. Evenly tighten and torque u-bolt nuts. See Specific Bolt Torques on Page 2-2.
7. If additional trailer axles are available, use the same procedures but from previous axle aligned and repeat steps 2-6.

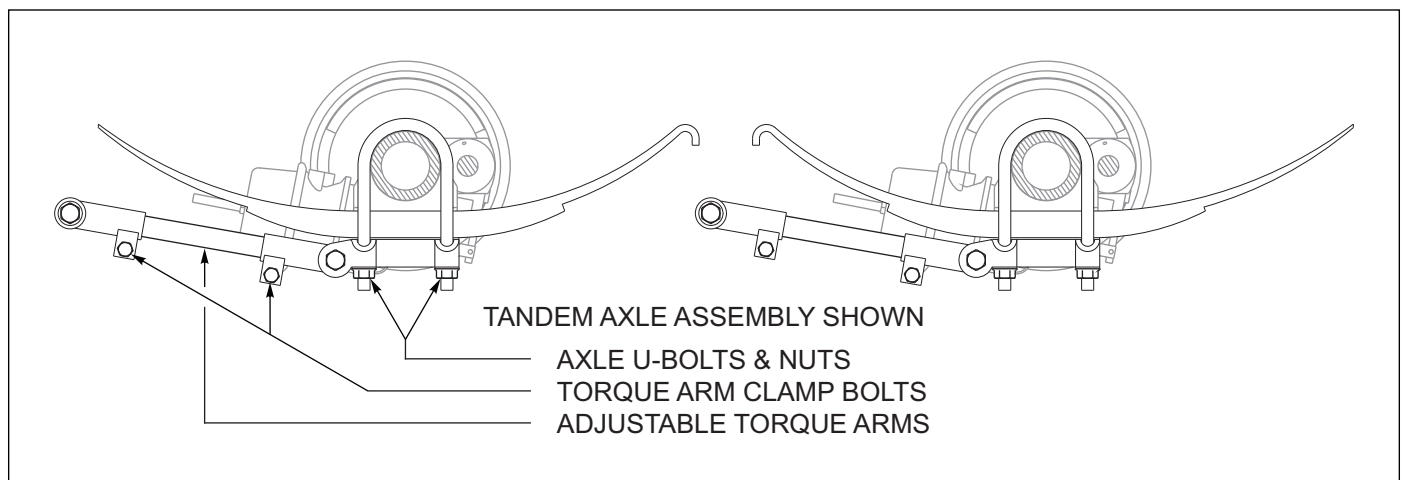

Figure 4-10: Spring Ride Adjustable Torque Arm

Brake System Maintenance



WARNING

Use great care if wheels or brake drums must be handled. They may be very hot and can cause serious injury.

General

1. Check air hoses for chafing, bends, kinks, or damaged fittings. Replace defective hoses.
2. Check the brake system for loose, missing, deformed, or corroded fastenings. Replace and tighten defective hardware.
3. Check brake linings for excessive wear or distortion. (See Figure 4-12.)
4. Drain air reservoir daily. A drain cock on the bottom of each air reservoir vents the tank to drain collected water and oil. If held open, air pressure in the tanks is relieved, causing the emergency or parking brakes to be applied (See Figure 4-11.)

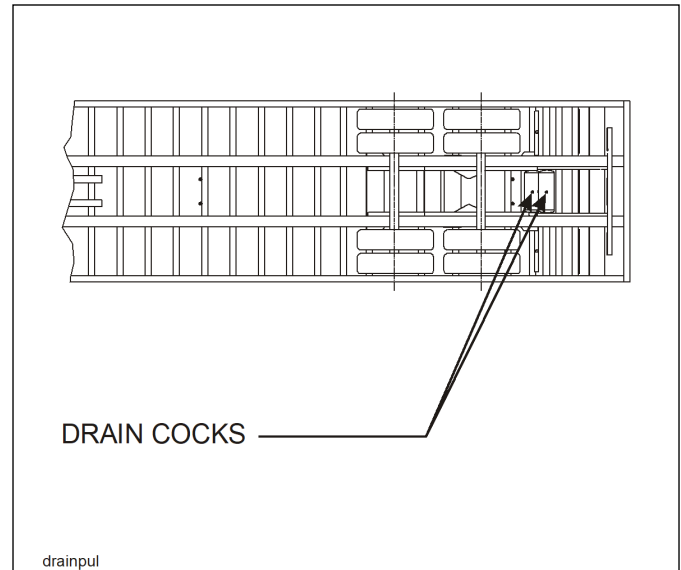

Figure 4-11: Drain Cock Locations

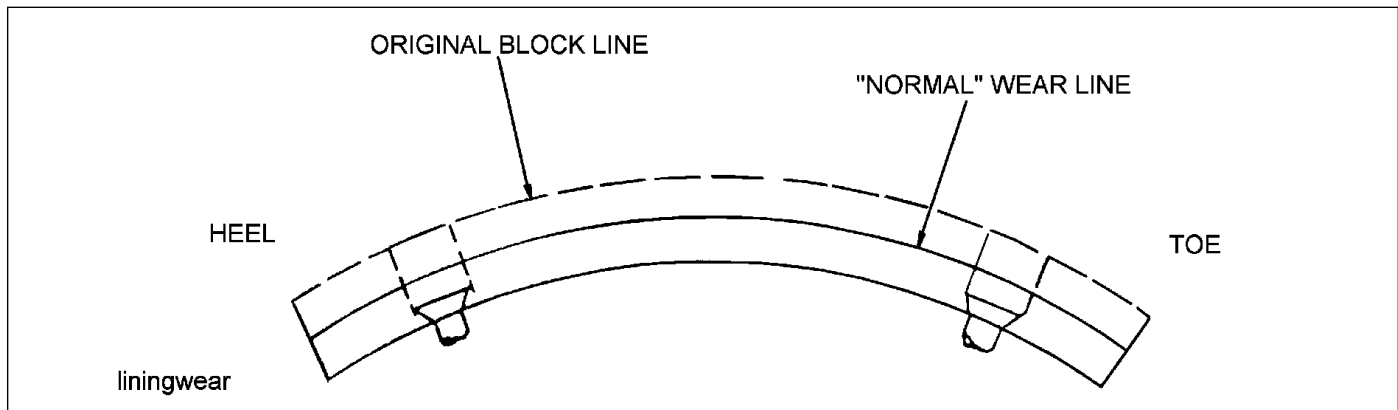

Figure 4-12: Brake Lining Wear

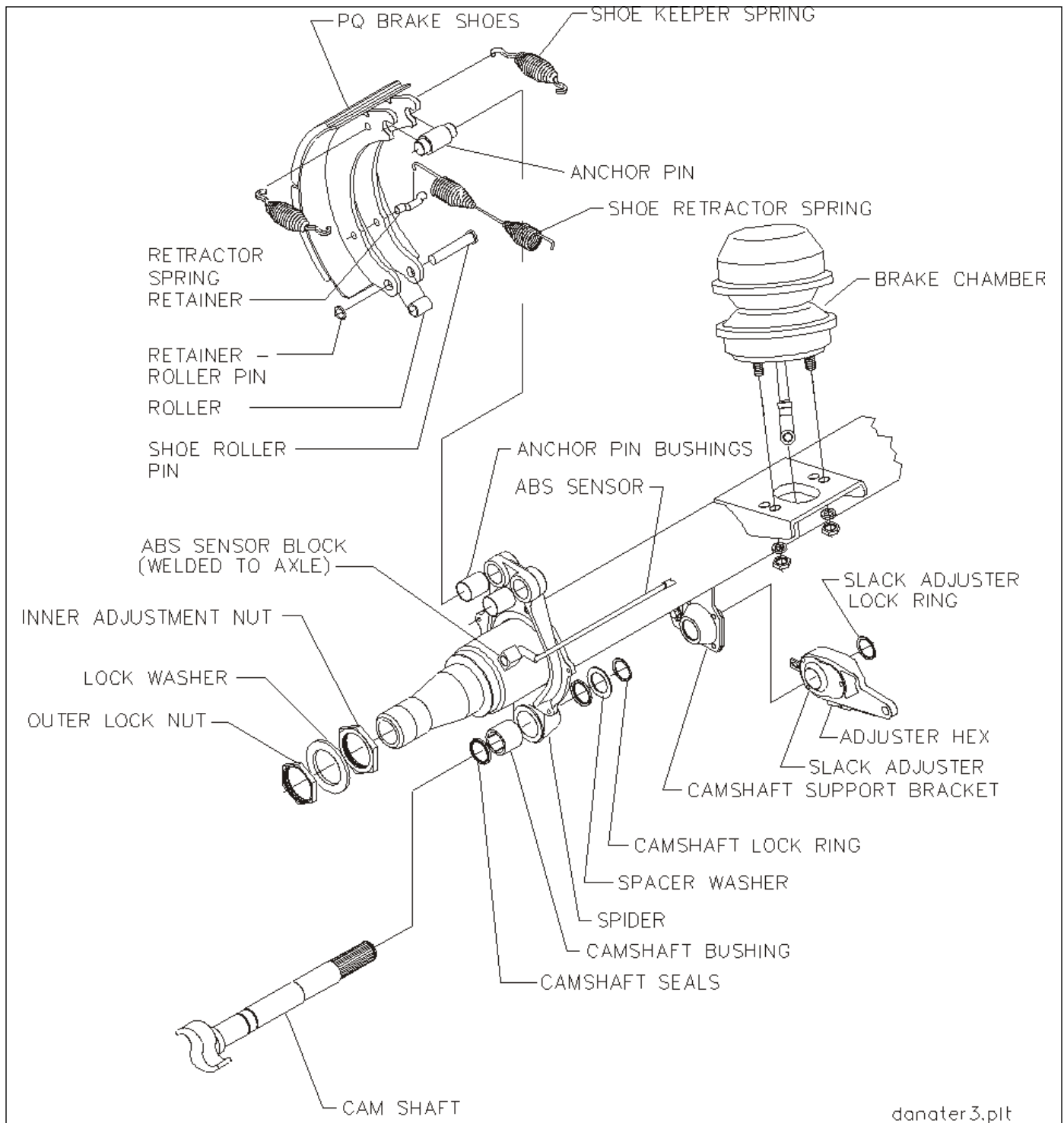

Figure 4-13: Axle and Brake Assembly

Spring Air Brake Chamber

Repair or replace faulty units. Check the condensation holes on the underside of the brake chambers to make sure they are open. The spring brake has two brake chambers, a service chamber and an emergency chamber or spring chamber. Service brake chambers should be disassembled and cleaned at 50,000 miles or

yearly. The diaphragm and any marginal parts should be replaced. The spring chamber should not be serviced. Replace entire unit if spring chamber becomes faulty. When replacing the service diaphragm, replace the corresponding parts for the other chamber on the same axle (to aid in even brake application and release). Examine yoke pin for wear and replace as necessary.



WARNING

The spring brake chamber employs a spring with high forces. Service should not be attempted. Serious injury or death may result.

Caging the Power Spring

1. Chock the semitrailer wheels.
2. Remove dust cap from spring brake chamber.
3. Remove the release bolt from its holding brackets and insert it into the spring brake chamber. **DO NOT USE AN IMPACT WRENCH TO CAGE THE SPRING BRAKE!**
4. Turn the bolt until the spring brake is caged. This should be 2-1/4 to 2-1/2 inches of release bolt extension.
5. The brakes should now be released. Do not operate loaded semitrailer with brake manually released.
6. To reset the spring brake, turn the release bolt until the spring is released. Remove the release bolt and store it in its brackets.
7. Snap the dust cap back in place on the chamber.

Removal

1. Chock all tractor and semitrailer wheels and drain the air system.
2. Mark the brake chamber for proper air line port alignment for reassembly.
3. CAGE THE POWER SPRING following the steps outlined in “Caging the Power Spring” on page 4-22.
4. Disconnect the slack adjuster from the connecting rod by removing the clevis pin (See Figure 4-13.)
5. Mark all air service lines for proper reinstallation and disconnect from the brake chamber.
6. Remove the brake chamber from the axle brackets.

Installation

1. CAGE THE POWER SPRING following the steps outlined in “Caging the Power Spring” on page 4-22.
2. Position the inlet ports by loosening the service chamber clamp bands and rotating the center housing so the ports align with marks made during disassembly. Then retighten the clamp bands.
3. Loosen the clamp bands on the spring brake chamber and rotate the chamber housing until the breather hole faces downward. Retighten the clamp bands.
4. Remount the brake chamber on the axle brackets and reconnect the air service hoses and the slack adjuster connecting rod (See Figure 4-14.)

IMPORTANT

Be sure the service line is on the service chamber port and the emergency line is on the spring brake port.

5. Check for leakage by charging the air system to a minimum of 90 psi and applying soap suds to the brake chamber and connections. If a growing bubble is detected or bubbles are blown away, locate the source of the leak and repair.
6. Insure that the clamp band is properly seated and tight **before** uncaging the power spring.

Tandem Relay Valve Maintenance

Every 3600 operating hours, 100,000 miles, or yearly, the Relay Emergency Valve should be disassembled, cleaned, and lubricated by a trained technician.



WARNING

Repair or replacement of the relay/emergency valve is a complex operation and should be performed by trained service personnel. Contact a landoll authorized service center for servicing.

Brake Assembly Maintenance

The brake assemblies should be inspected and adjusted every 2,000 miles or monthly. Examine the brake linings visually to locate the lining showing the greatest amount of wear. The wheel and drum should be removed and the linings replaced if the thinnest portion of the lining is 3/8 in. (9.5 mm) or less. Do not allow the linings to wear thin enough that the lining rivet contacts the drum (See Figure .)



WARNING

Do not allow grease to contact brake linings as this could result in reduced braking performance.

Brake Adjustment

Slack adjusters provide the means for routine brake adjustment to compensate for lining wear. Inspect and adjust slack adjusters weekly or at 2,000 mile intervals.

1. To check adjustment release brakes.
2. Measure the distance (D1) from the face of the brake air chamber to the center of the slack adjuster linkage pin (**See Figure 4-14.**)
3. Apply brakes.
4. Repeat **step 2** to measure the distance (D2).
5. Subtract the two distances to find the air chamber push rod travel. The total travel of the brake push rod must be less than 1-3/4" to meet Federal "IN-SERVICE" criteria. It is advisable to adjust all brakes on the same axle to within 1/2" of each other to prevent unbalanced braking.
6. To adjust, release brakes.
7. Place a 9/16" box end or socket wrench on the slack adjuster adjusting nut (**See Figure 4-14**), and push in on the locking sleeve.
8. Adjust by rotating the adjusting nut counterclockwise to loosen the brake and clockwise to tighten the brake.
9. Remeasure air chamber push rod travel from release to full brake application. If the adjustment is not within the "IN-SERVICE" criteria readjust. If the adjustment has brought the travel to within specifications, proceed to the next step.
10. Remove wrench from slack adjuster. Check locking sleeve to verify that it has sprung back out and is locking the adjusting nut. If not, the adjuster will have to be rotated slightly.

Disassembly

1. Release brakes and back off slack adjuster, (**See Figure 4-13.**)
2. Remove slack adjuster lock ring and slack adjuster.
3. Remove drum assembly.
4. Disengage the roller retainers from the rollers.
5. Press down on the bottom brake shoe and remove the lower cam roller. Lift the top shoe and take out the top cam roller.
6. Lift out the shoe retractor spring, which is now free of tension.
7. Swing the lower shoe back approximately 180° to relieve the tension on the shoe keeper springs. Remove the springs and slip the shoes off the anchor pins.
8. Remove camshaft lock ring, spacer washer(s) and camshaft.
9. After removing the shoes, completely inspect all brake components, servicing as necessary.

Reassembly

1. Install new anchor pin bushings, camshaft bushing, and camshaft seals into the spider.

IMPORTANT

When installing camshaft seals, the seal on the slack adjuster side is installed facing into the spider. This allows grease to purge outside the brake assembly when greasing the camshaft bushing.

2. Install cam roller, retainer clip and retractor spring retainers onto the brake shoes.
3. Install 1/8" thick camshaft washer onto the camshaft.
4. Install the cam shaft into the spider. Install spacer washer and lock ring retainer on camshaft before sliding the camshaft through the camshaft support bracket. Install the slack adjuster, washer, and lock ring retainer.
5. Install the brake keeper springs onto the shoes. Install shoes onto the spider by placing shoes in place on the anchor pins, then "wrap" the two shoes into place about the spider.
6. Install the shoe retractor spring onto the shoes.
7. Connect the slack adjuster to the brake chamber pushrod.
8. Adjust brakes as outlined in brake adjustment procedures.

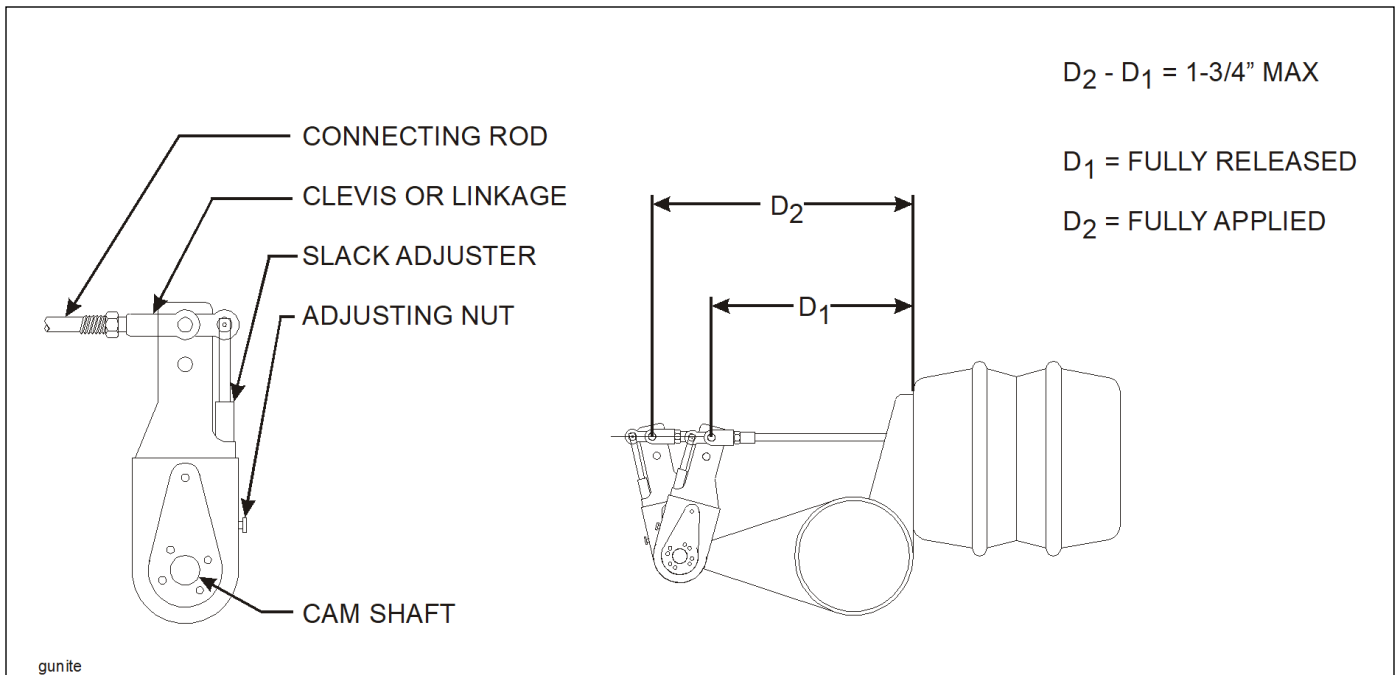

Figure 4-14: Checking Brake Adjustment

Brake Adjustment

Slack adjusters provide the means for routine brake adjustment to compensate for lining wear. Inspect and adjust slack adjusters weekly or at 2,000 mile intervals.

1. To check adjustment release brakes.
2. Measure the distance (D1) from the face of the brake air chamber to the center of the slack adjuster linkage pin (See Figure 4-14.)
3. Apply brakes.
4. Repeat **step 2** to measure the distance (D2).
5. Subtract the two distances to find the air chamber push rod travel. The total travel of the brake push rod must be less than 1-3/4" to meet Federal "IN-SERVICE" criteria. It is advisable to adjust all brakes on the same axle to within 1/2" of each other to prevent unbalanced braking.
6. To adjust, release brakes.
7. Place a 9/16" box end or socket wrench on the slack adjuster adjusting nut (See Figure 4-14), and push in on the locking sleeve.
8. Adjust by rotating the adjusting nut counterclockwise to loosen the brake and clockwise to tighten the brake.
9. Remeasure air chamber push rod travel from release to full brake application. If the adjustment is not within the "IN-SERVICE" criteria readjust. If the adjustment has brought the travel to within specifications, proceed to the next step.

10. Remove wrench from slack adjuster. Check locking sleeve to verify that it has sprung back out and is locking the adjusting nut. If not, the adjuster will have to be rotated slightly.

Disassembly

1. Release brakes and back off slack adjuster, (See Figure 4-13.)
2. Remove slack adjuster lock ring and slack adjuster.
3. Remove drum assembly.
4. Disengage the roller retainers from the rollers.
5. Press down on the bottom brake shoe and remove the lower cam roller. Lift the top shoe and take out the top cam roller.
6. Lift out the shoe retractor spring, which is now free of tension.
7. Swing the lower shoe back approximately 180° to relieve the tension on the shoe keeper springs. Remove the springs and slip the shoes off the anchor pins.
8. Remove camshaft lock ring, spacer washer(s) and camshaft.
9. After removing the shoes, completely inspect all brake components, servicing as necessary.

Reassembly

1. Install new anchor pin bushings, camshaft bushing, and camshaft seals into the spider.

IMPORTANT

When installing camshaft seals, the seal on the slack adjuster side is installed facing into the spider. This allows grease to purge outside the brake assembly when greasing the camshaft bushing.

2. Install cam roller, retainer clip and retractor spring retainers onto the brake shoes.
3. Install 1/8" thick camshaft washer onto the camshaft.
4. Install the cam shaft into the spider. Install spacer washer and lock ring retainer on camshaft before sliding the camshaft through the camshaft support bracket. Install the slack adjuster, washer, and lock ring retainer.
5. Install the brake keeper springs onto the shoes. Install shoes onto the spider by placing shoes in place on the anchor pins, then "wrap" the two shoes into place about the spider.
6. Install the shoe retractor spring onto the shoes.
7. Connect the slack adjuster to the brake chamber pushrod.
8. Adjust brakes as outlined in brake adjustment procedures.

Hub and Drum Maintenance

1. Clean and inspect the brake drums whenever relining the brakes. To be suitable for further service, the brake drum should pass the following checks.
 - a. The brake surface should be free of scoring, excessive heat checks and cracks.
 - b. The brake surface diameter should be within the maximum diameter cast or stamped on the drum.
 - c. The mounting holes and pilot must be round and true.
 - d. The mounting surface must be clean and flat.



WARNING

Failure to replace faulty brake drums will result in an unreliable braking system, and may lead to an accident.

2. It may be necessary to turn or resurface the braking surface to remove small heat checks or other surface defects resulting from normal use.

3. The maximum diameter cast into the back plate portion of the brake drum is the maximum diameter or discard diameter to which the brake drum may be turned or worn and still be usable. If any portion of the brake surface exceeds the maximum diameter it must be discarded. The maximum is .120 over the nominal new diameter unless stated otherwise on the casting. The maximum diameter cast into the brake drum supersedes all published information.
4. When resurfacing a drum, allow at least 0.040 inches under the maximum diameter for additional wear.



WARNING

Turning a brake drum beyond 0.040 inches under the maximum diameter will result in a weaker brake drum and may result in an accident.

5. Replacement of the brake drum is required if any of the following conditions exist:
 - a. The brake drum is cracked.
 - b. The brake surface is heat checked, grooved or worn beyond the rebore limit or the maximum diameter.
 - c. The back plate is cracked.
 - d. The bolt holes are elongated.
 - e. The brake drum has been severely overheated.
 - f. The brake drum is out-of-round.



CAUTION

Replace brake drums in pairs to achieve the same braking power on both wheels and maintain an even braking load on the axle. Failure to do this may significantly reduce the performance, service life, and/or safety of your vehicle.

6. For aluminum wheels, often a separator plate is used (**See Figure 4-19.**) The separator plate is approximately .040" thick. It is placed between the drum and the wheel, or between two wheels in dual applications. The separator plate is recommended in severe applications where corrosion and/or wear have been identified. Aluminum wheels benefit from use of the separator plate. Care must be exercised in centering the separator plate prior to torquing, and stud length must be checked as each plate is approximately .040" thick.

7. Replace the hub and drum as follows (See [Figure 4-15.](#)):
- Remove the brake drum (See [Figure 4-15.](#)) It may be necessary to release the slack adjuster.
 - Remove hub cap and catch lubricant in a pan.
 - Remove outer spindle nut, spindle locking washer, inner spindle nut, and bearing. Remove hub from axle.
 - Using an appropriate driver, remove inner bearing cone, and seal.
 - Using an appropriate driver, remove bearing cups from hub.
 - Check that the hub cavity is clean. If the hub is to be reused, clean it thoroughly.
 - Insert bearing cups into the hub.
 - Clean the mounting surfaces with a good grade commercial cleaner and soft rag. Dry all component parts with a clean, absorbent cloth or paper. Lubricant will not adhere to surfaces wet with solvent.
 - Install inner bearing, cone, and seal.

- Place the hub or wheel over the axle spindle being careful to align the hub bore with the axle. Do not damage the seal. Support the hub assembly until the outer bearing cone and spindle nut are installed, to avoid damaging the seal.
- Install the outer bearing cone and inner spindle nut, tightening the nut until it is snug against the outer bearing cone. Remove the hub support allowing the hub to rest on the bearings.
- Install and adjust bearings (See [“Wheel Bearing Lubrication and Adjustment”](#) on page 4-27.)
- Install the hub cap with the proper gasket. Tighten the cap screws of the hub cap to 10 to 15 ft-lbs. of torque.
- Remove the filler plug and fill the hub cavity to the recommended level with a gear type oil.
- Place the drum over the hub and brake shoes being careful not to damage the threads on the studs. Make sure the drum seats flat against the hub flange and mates properly with the hub pilot. There should be no interference between the brake drum pilot chamfer and the corner radius on the hub. If interference exists, the hub will not be able to function properly.

IMPORTANT

Do not mix new cups with old cones or new cones with old cups.

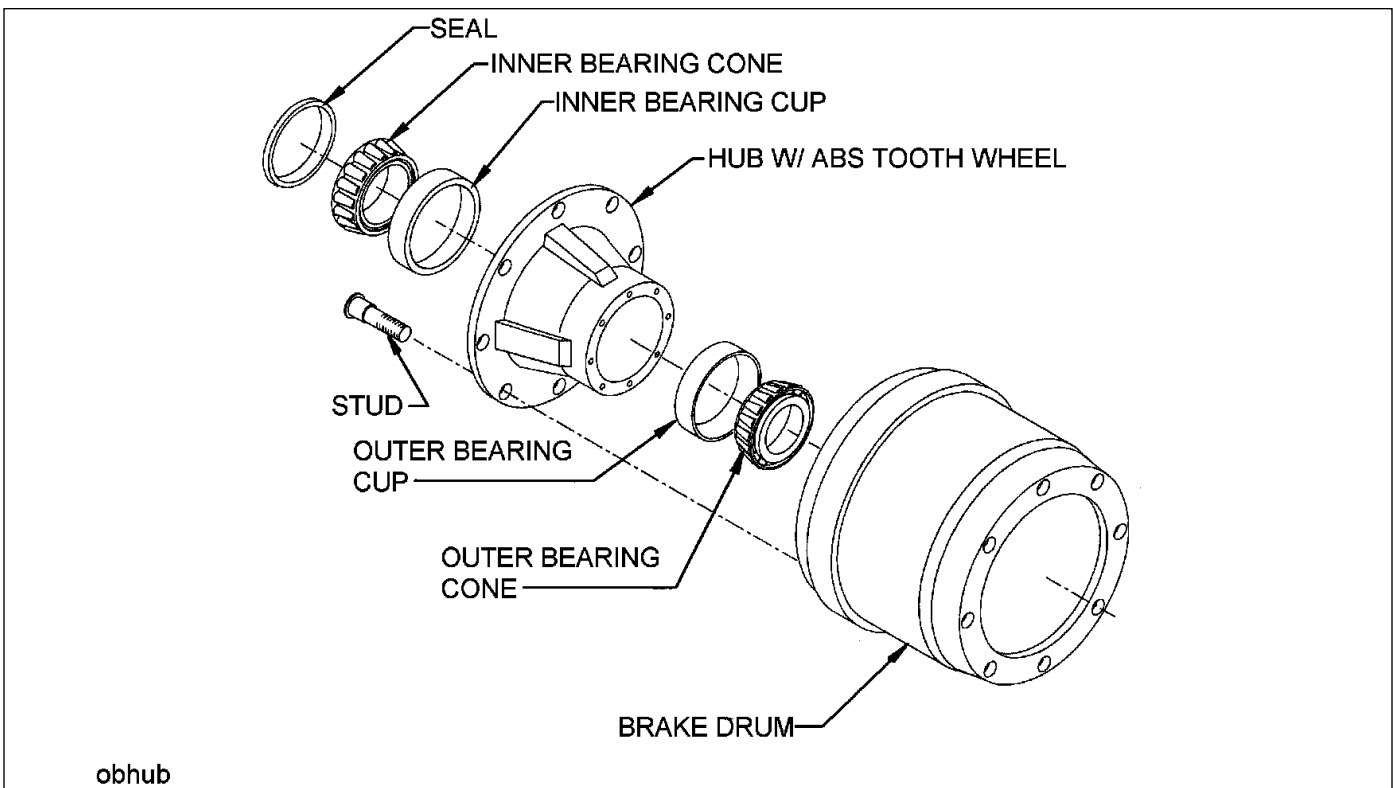

Figure 4-15: Outboard Mount Hub and Drum

Wheel Bearing Lubrication and Adjustment

With semitrailer sitting level, the oil level must be checked daily and maintained between the “ADD” and “FULL” lines on the hub cap window. Check for cracked windows, missing filler plugs, and oil leaks. Add hub oil through the “POP-IN” filler plug located in the center of the hub windows. Reinstall the “POP-IN” plugs after filling each hub. Adjust wheel bearings and change oil every 50,000 miles or with each brake lining replacement, whichever occurs first.

Adjustment

1. With a drain pan under the hub cap, remove the hub cap assembly allowing oil to drain.
2. Lift the wheel off of the ground.
3. Adjust slack adjuster to eliminate brake drag during tire/wheel rotation.
4. Remove outer lock nut and inner nut and lock washer.
5. Tighten the inner adjustment nut to a minimum of 75 ft-lbs, while rotating wheel to insure proper seating of the bearings and cups in the wheel hub.
6. Loosen the inner adjustment nut so that the wheel will turn freely.
7. Retighten the inner adjustment nut to 50 ft-lbs while rotating the wheel, to properly position the bearings for the final adjustment.
8. Loosen the inner adjustment nut 1/3 turn.
9. Install the spindle nut lock washer so that the dowel on the inner nut will align with a hole in the lock washer and the washer tang fits in the spindle keyway.
10. Install the outer lock nut and tighten to 250-300 ft-lbs. End-play of .001" to .010" must be present in the adjusted wheel bearing assembly.
11. Install the hub cap with a new gasket, torque 10 to 15 ft-lbs, and fill with oil to the full mark. Use 90 weight gear oil.
12. Adjust brakes according to “[Brake Adjustment](#)” on [page 4-24](#).



DANGER

Failure to torque the outer lock nut properly could cause the wheel to come off during vehicle operation resulting in property damage or loss of life.

13. Check hub oil level after the wheel has set level in one position for a few minutes to allow the oil to work into the bearings.

Tire Maintenance

Tire Inflation

Tire inflation will cause tire to ground contact characteristics as shown in [Figure 4-16](#). Tire inflation should be checked daily while the tire is cold, and during road stops. Checking the tire pressures while tires are hot will give a faulty increased pressure reading. Adjusting tire air pressure to the specified amount while tires are hot will produce improper tire to road contact and thus abnormal wear. Do not exceed cold inflation pressure listed on the semitrailer VIN plate located on the front of the semitrailer. Exceeding cold inflation pressure will result in damaged tire bodies, rims, and wheels. Replace all valve stem caps when pressure checking/adjusting has been completed. Remove any foreign objects from between duals.

Tire Matching

Both tires on the same spindle must be the same size in order to properly distribute the load and braking forces between them. The tire must be mounted on a rim and properly inflated before measuring. If there is an allowable difference in size the smaller tire should be mounted to the inside position of the duals.

Tape Measuring Method

Measure around each tire on the tread surface. A maximum difference of 3/4" is allowed between the two mating tires of a dual ([See Figure 4-17](#).)

Straight Edge or String Method

(This method can not be used if tire and wheel assemblies are not mounted on the axle.) Jack semitrailer up until the wheels are off of the ground. Hold a straight edge against the tires of both ends of an axle. A gap at one tire indicates a smaller tire. A maximum of 1/8" gap is allowed ([See Figure 4-18](#).)

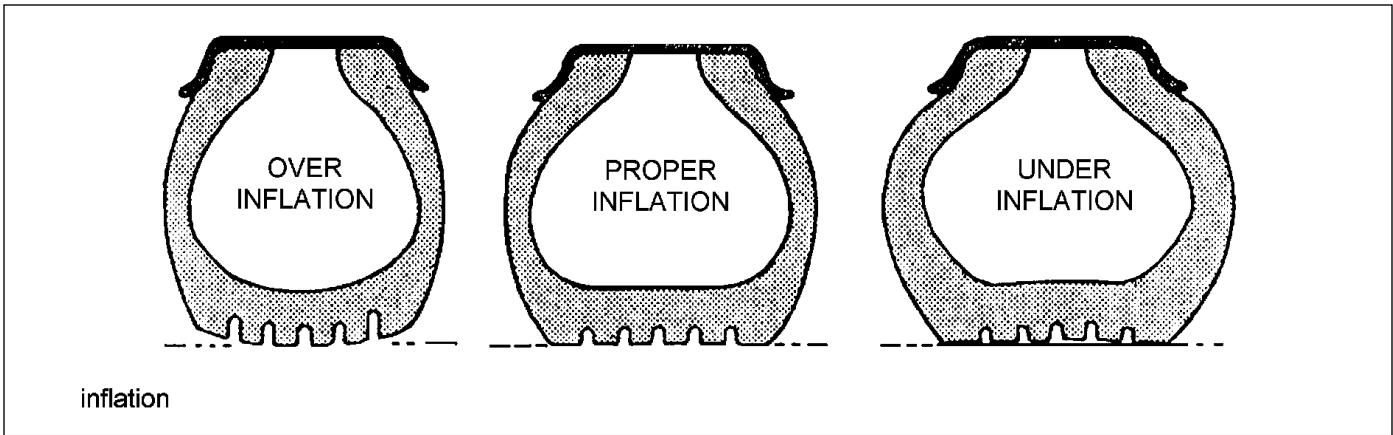

Figure 4-16: Tire Inflation Examples

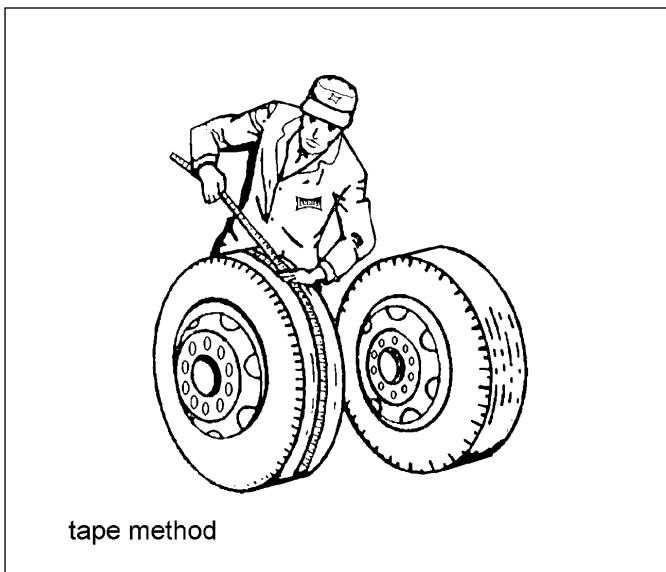

Figure 4-17: Measuring Tape Method

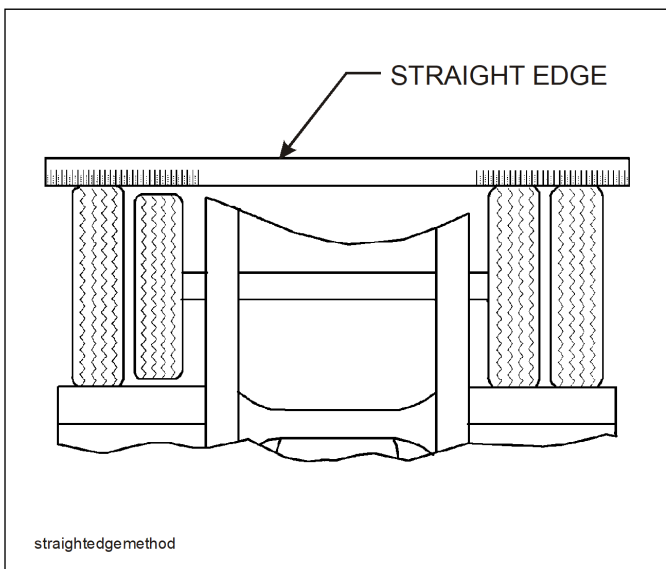

Figure 4-18: Straight Edge Method

Mounting Tire and Wheel

1. Make sure that all mounting surfaces are clean and free of rust, dirt or paint. A wire brush may be used to clean these surfaces (See Figure 4-19.)
2. Position the inner disc wheel over the studs, being careful not to damage the stud threads. Make sure that the disc wheel is flat against the mounting surface and that there is clearance between the disc wheel taper and brake drum.
3. Install the inner capnuts on the studs and tighten to fifty ft-lbs using the sequence illustrated in **Figure 4-20**. Make certain that the left-handed threads are installed on the driver side of the vehicle and the right-handed threads are installed on the curbside of the vehicle.
4. Tighten the inner capnuts to full torque of 450 to 500 ft-lbs using the sequence shown in **Figure 4-20**.
5. Position the outer disc wheel over the capnuts being careful not to damage the inner capnut threads. Be sure the valve stems for both the inner and outer tire are accessible.
6. Install the outer capnuts and tighten to 50 ft-lbs using the sequence in **Figure 4-20**. Then tighten to full torque of 450 to 500 ft-lbs using the same sequence.
7. Torque will drop after the first 50 to 100 miles of operation. Check the capnuts for proper torque after this interval and retighten them. Loosen the outer capnuts and retighten the inner and outer capnuts per Steps 4 to 6.



WARNING

Use a torque wrench to assure proper torque. Insufficient torque can cause stud breakage and damage wheel pilots. Overtorque can overstress the studs and strip the threads.

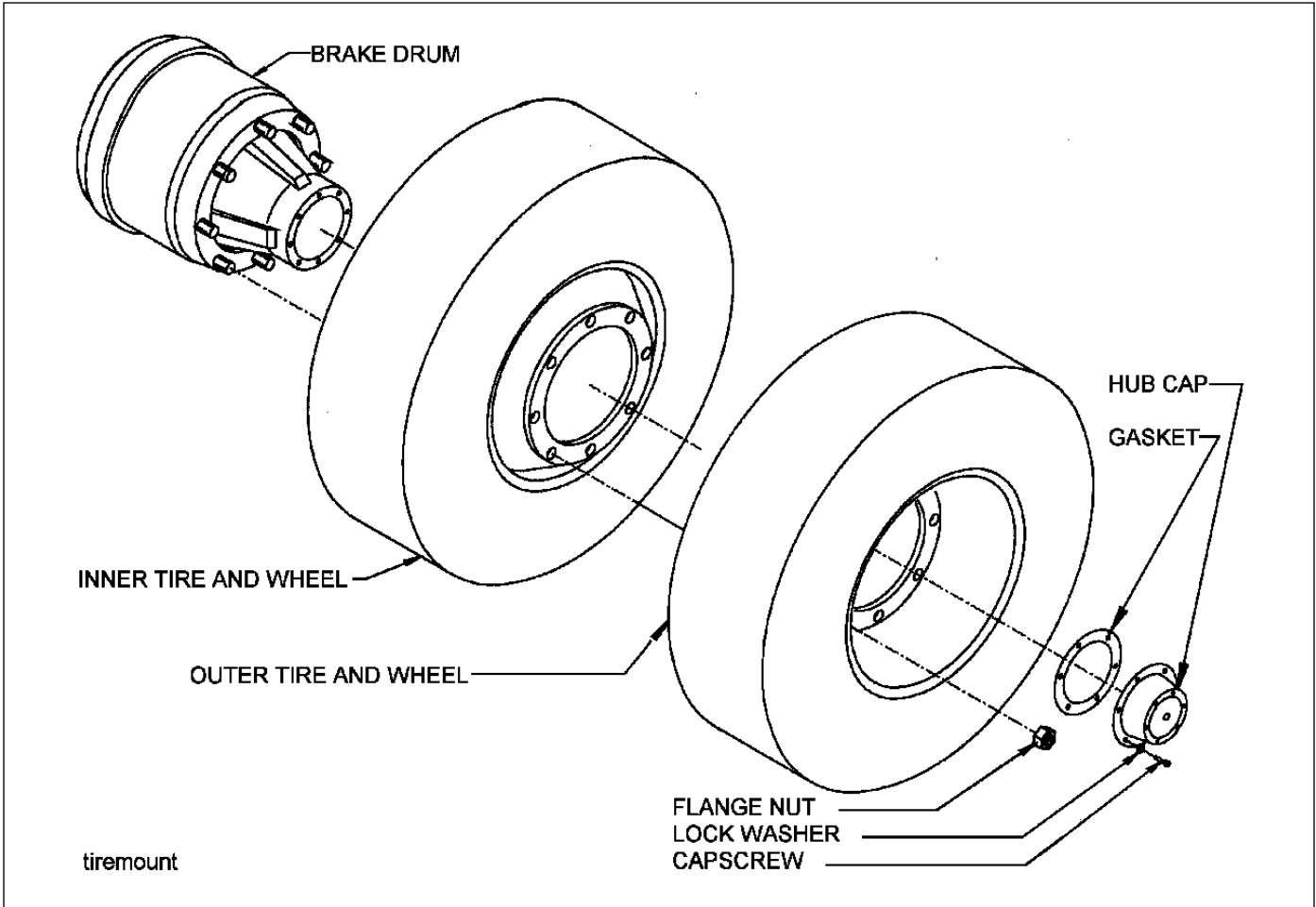

Figure 4-19: Mounting Tires and Wheels

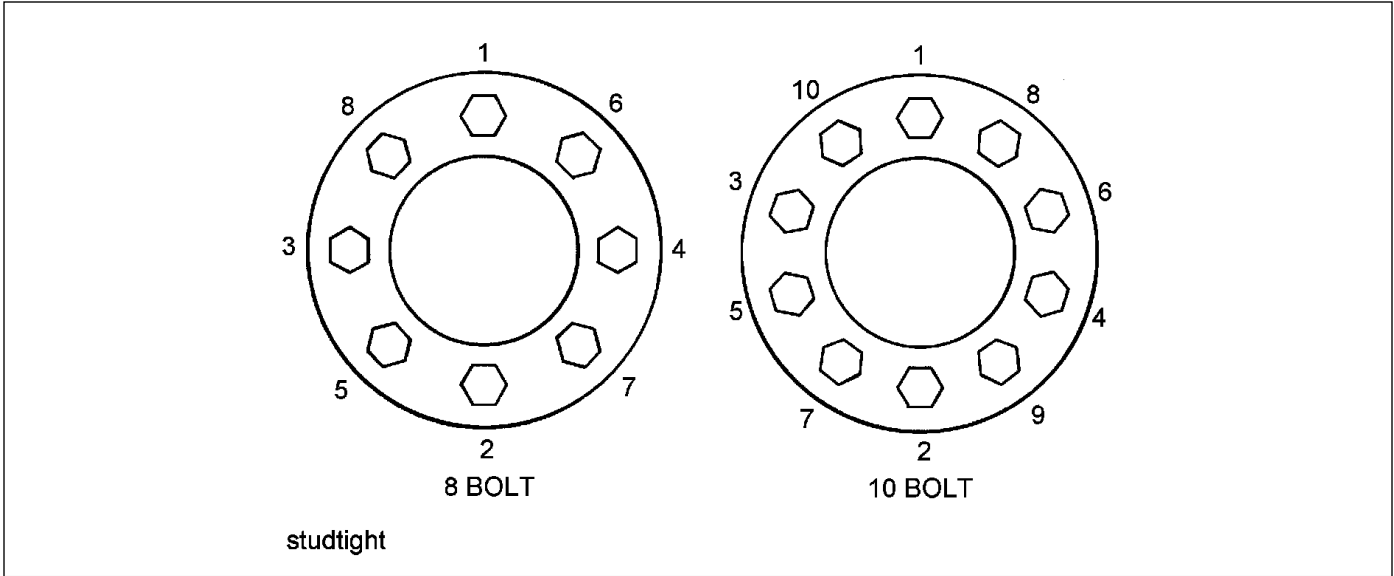

Figure 4-20: Stud Tightening Sequence

Gearbox Maintenance

1. Inspect the gearbox chain before and after every usage. If nicks, kinks, worn spots, breaks or any other sign of deterioration or damage is found, immediate replacement is mandatory before further usage. If the semitrailer is going to be out in the weather for any length of time, it is advisable to oil the chain drive to prevent untimely rusting and deterioration of the chain. **See Table 4-1** for lubrication specifications.
2. If the gearbox chain has more than 1/32" wear in the links, the chain needs to be replaced. If the chain needs to be replaced or if links need to be taken out in order to get the chain tight, one of the chain links will need to be cut and welded back together. A chain splice p/n 129214 is used to aid in splicing the chain back together. Use stainless steel missile rod (Welco Super Missile Weld 120,000 psi tensile strength) to weld the link back together.
3. Inspect the chain drive mechanism thoroughly each week to insure safe, efficient operation.
4. If the chain is loose, it needs to be tightened before loading a load. This is done at the gearbox.
 - a. Loosen the four screws that hold gearbox to the mounting plate.
 - b. Pull the gearbox forward using the adjusting screws.
 - c. Do not put more than 12,000 pounds of pull on the gearbox so each screw should have no more than 6,000 pounds of pull on it. Torque of 90 ft.-lbs on 7/8-9 non-oiled, clean thread should create 6,000 pounds tension.



WARNING

Do not handle the chain drive when the chain drive is in the engage position. Hands or clothing could get caught in the chain and be pulled into the spool causing serious personal injury.

Winches

Inspect the winch cable before and after **every** usage. If frayed wires, nicks, kinks, worn spots, breaks or any other sign of deterioration or damage is found, immediate replacement is mandatory before further usage. If the semitrailer is going to be out in the weather for any length of time, it is advisable to oil the winch cable to prevent untimely rusting and deterioration of the cable.

Inspect the winch mechanism thoroughly each week to insure safe, efficient operation.



WARNING

Do not handle the winch cable when the winch is in the engage position. Hands or clothing could get caught in the cable and be pulled into the spool causing serious personal injury.

Troubleshooting Guide

Troubleshooting should be performed by a trained and competent technician. Landoll Company, LLC. is not responsible for equipment that is improperly maintained. Contact an authorized Landoll Service center for servicing.

Electrical

Most electrical system problems show up as a burned out light or fuse, or inoperative electrical component. Wiring, grounds, or components may be at fault. Locate the symptom in this section that best identifies your electrical problem. Check out each possible problem under that symptom. If the problem cannot be located, see an automotive electrical specialist. For maintenance procedures see **“Electrical System” on page 4-11.**

PROBLEM	PROBABLE CAUSE	SOLUTION
NO LIGHTS	Fuse blown	Replace fuse
	Connection at plug-in	Tighten connection
	Broken or corroded wires	Replace wire
	Ground wire loose	Clean and tighten ground
LIGHTS FLICKERING	Wires shorted or loose	Locate, insulate, replace, or tighten
	Grounding through fifth wheel	Locate broken ground wire (tractor or semitrailer)
LIGHTS DIM	Voltage difference between semitrailer and tractor	Match bulbs with tractor voltage
	Grounding through fifth wheel	Locate broken ground wire (tractor or semitrailer)
LIGHTS BRIGHT AND BURN OUT	Voltage difference between semitrailer and tractor	Match bulbs with tractor voltage
FUSE BLOW-OUT OR CIRCUIT BREAKER TRIPPING	Vibration	Locate source of vibration and repair
	Short circuit	Replace fuse and try all accessories. If fuse blows right away, locate short and repair
LAMP BULB BURN OUT	Vibration	Locate source of vibration and repair
	Short circuit	Replace fuse and try all accessories. If fuse blows right away, locate short and repair
	Loose connection	Check lamp sockets and ground connections
	Intermittent short	Locate short and repair
	Improper voltage	Check voltage regulator output

Tires - Wheels - Suspension

Most tire, wheel, and suspension related problems are due to excessive loads, extreme conditions, and improper maintenance. Tire, wheel, and suspension problems can be easily detected and solved by checking the following guide. For maintenance procedures, refer to the following sections:

- “Suspension Maintenance” on page 4-14
- “Axle Alignment” on page 4-17
- “Hub and Drum Maintenance” on page 4-25
- “Wheel Bearing Lubrication and Adjustment” on page 4-27
- “Tire Maintenance” on page 4-27

PROBLEM	PROBABLE CAUSE	SOLUTION
VIBRATIONS WHILE DRIVING	Improper tire inflation	Inflate to proper pressure (See “Tire Inflation” on page 4-27.)
	Tires cupped or have flat spots	Replace tires.
	Wheels bent or loose	Replace or tighten.
	Tires incorrectly mounted	Remount (See “Mounting Tire and Wheel” on page 4-28.)
	Mud in wheels	Clean wheels.
	Tire(s) out of balance	Balance tires.
	Brakes dragging	Locate cause and repair.
Object(s) stuck between duals	Remove object(s).	
RAPID TIRE WEAR/DETERIORATION:		
CENTER TREAD WEAR	Over inflation	Deflate to correct inflation (See “Tire Inflation” on page 4-27.)
SHOULDER TREAD WEAR - BOTH SHOULDERS	Under inflation	Increase inflation to correct PSI. Check axle alignment (See “Tire Inflation” on page 4-27.)
	Overload	Loads are above rated tire capacity. DO NOT load above rated tire capacity.
SHOULDER TREAD WEAR - ONE SHOULDER	Axle damage	Straighten or replace axle (See “Axle Alignment” on page 4-17.)
	Axles not parallel	Check axle alignment.
OVERALL TREAD WEAR	Overloading	Check tire load rating.
	High speeds	Adjust speed according to road and load conditions.
	Incorrect dual matching	Properly match dual tires (See “Tire Matching” on page 4-27.)
TIRE FLAT SPOTS	Quick stops	Adjust braking practices.
	Grabbing brakes	Adjust brakes properly (See “Brake Adjustment” on page 4-24.)
	Worn or loose wheel bearings	Adjust or replace as needed (See “Hub and Drum Maintenance” on page 4-25.)
	Out of balance wheels and tire	Balance wheels and tires. Check ABS system function.
UNEVEN WEAR	Suspension bushings worn	Replace bushings (See “Hub and Drum Maintenance” on page 4-25.)
	Worn or loose wheel bearings	Adjust or replace as needed.
	Out of balance wheels and tires	Balance wheels and tires.
RIM FAILURE*:		
CRACKING	Overinflated tires	Deflate tire to proper PSI.
	High speeds	Adjust speed according to road and load conditions.
	High speed cornering	Adjust cornering practices.
	Over loading	Check rim load rating.
*IN ALL INSTANCES OF RIM FAILURE, REPLACE THE RIM IMMEDIATELY!		

Brakes

For maintenance procedures, see “**Brake System Maintenance**” on page 4-20.

PROBLEM	PROBABLE CAUSE	SOLUTION
NO BRAKES OR BRAKES ARE INTERMITTENT	Brake air system improperly connected	Reconnect hand valves properly.
	Relay/Emergency valve plugged	Clean valve.
	Defective tractor protection valve	Repair or replace.
	Restricted tubing or hose line	Locate and eliminate restriction.
	Broken line	Locate break and repair.
	Tractor air system failure	Troubleshoot tractor air system and repair. Check ABS system function.
SINGLE BRAKE DRAGGING OR LOCKED	Broken internal brake component	Locate and replace broken part (See “ Brake System Maintenance ” on page 4-20.)
	Flat spot on cam roller or cam shaft	Replace and lubricate.
	Improper adjustment	Adjust slack adjusters
	Spider bushing or cam bracket bushing binding	Lubricate or replace bushing.
	Improper lubrication	Lubricate per Figure 4-1 .
	Worn brake shoe bushing	Replace bushing.
	Brake drum distortion	Replace drum.
	Broken brake chamber spring	Replace spring.
	Brake chamber pushrod binding	Realign brake chamber bracket.
	Air brake line loose or broken	Tighten or repair.
UNEVEN BRAKES	See “SINGLE BRAKE DRAGGING OR LOCKED”	
	Restriction in hose	Locate restriction and remove
	Worn brake linings	Reline brakes.
	Grease on linings	Reline brakes.
	Broken slack adjuster	Replace slack adjuster
	Leaking brake chamber diaphragm	Replace diaphragm.
BRAKES APPLY TOO SLOWLY	Brakes need adjusting or lubrication	Adjust or lubricate as needed.
	Low air pressure in brake system (below 105 PSI)	Check tractor air system.
	Restricted tubing or hose	Locate restriction and remove.
	Defective relay valve	Clean or replace.
	Call Factory or see qualified Trailer/Brake Technician	
BRAKES RELEASE TOO SLOWLY	Brakes need adjusting or lubrication	Adjust or lubricate as needed.
	Brake rigging binding	Align brakes or replace bent parts.
	Exhaust port of relay valve restricted or plugged	Clean valve.
	Tractor pressure too low	Adjust to provide 105 psi min.
ALL BRAKES DO NOT RELEASE	Air system improperly connected to tractor	Tighten or adjust connections.
	Brake valve on tractor is applied	Release brake
	Relay emergency valve in emergency position	Check line pressure and check valve position
	Restricted tubing or line	Locate restriction and remove
	Defective tractor protection valve	Troubleshoot tractor air system.
	Parking brakes locked	Troubleshoot air system
	Moisture in air system	Check air system
	Tractor pressure too low	Adjust to provide 105 psi min.

PROBLEM	PROBABLE CAUSE	SOLUTION
INSUFFICIENT BRAKES	Brakes need adjusting	Adjust brakes (See "Brake Adjustment" on page 4-24.)
	Brakes need lubricating	Lubricate brakes
	Brakes need relining	Reline brakes
	Low air pressure	Troubleshoot air system.
	Defective relay emergency valve	Repair or replace.
	Brakes overheated	Stop and allow brakes to cool, locate cause of overheating.
BRAKES GRABBING	Grease on brake linings	Reline brakes
	Brake rigging binding	Align brakes or replace bent parts.
	Defective brake valve on tractor	Repair or replace valve.
	Defective relay emergency valve	Repair or replace valve.
EXCESSIVE LEAKAGE WITH BRAKES RELEASED	Relay emergency valve leaking	Repair or replace valve
	Leaking tubing or hose	Replace defective part.
EXCESSIVE LEAKAGE WITH BRAKES APPLIED	Relay emergency valve leaking	Repair or replace valve.
	Leaking brake chamber diaphragm	Replace diaphragm.
	Call Factory or see qualified Trailer/Brake Technician	
	Leaking tubing or hose	Replace defective part.
EXCESSIVE LEAKAGE WITH EMERGENCY SYSTEM ONLY APPLIED - NO LEAKAGE WITH NORMAL BRAKING	Defective relay emergency valve	Repair or replace valve.
EXCESSIVE WATER PRESENT IN BRAKE SYSTEM	Reservoir not drained often enough	Drain reservoir daily.
EXCESSIVE OIL PRESENT IN BRAKE SYSTEM	Compressor on tractor passing excessive oil	Repair compressor.
BRAKE WILL NOT APPLY PROPERLY	Flat spot on cam roller or camshaft	Replace and lubricate.
BRAKES WILL NOT APPLY WHEN EMERGENCY LINE IS DISCONNECTED	Initial air pressure too low	Allow air system to build up to minimum 90 PSI and stabilize.
	Defective relay valve	Repair or replace valve.
	Air line leak	Locate leak and repair.
	Brake chamber leak	Locate leak and repair or replace.
ABS WARNING LIGHT STAYS ON	Refer to Rockwell WABCO ABS for system function and use of blink code diagnostics.	

Table provided for general use.

NOTES:

Brake Drums

For maintenance procedures, refer the following sections:

- “Suspension Maintenance” on page 4-14
- “Axle Alignment” on page 4-17
- “Brake System Maintenance” on page 4-20
- “Hub and Drum Maintenance” on page 4-25
- “Wheel Bearing Lubrication and Adjustment” on page 4-27

PROBLEM	PROBABLE CAUSE	SOLUTION
EXCESSIVE LOSS OF BRAKES OR FADING	Overheated brake drums	Check for defective or misadjusted brake linings, distorted or over-machined drums. Also check for operating conditions or loads that create severe or excessive brake applications.
BRAKES PULL TO EITHER SIDE	Drums of different diameters	Replace with drums of same diameter.
	Foreign matter in drums	Clean drums out.
ROUGH OR NOISY BRAKING ACTION	Defective drums	Pull drums and inspect for any of the following; Heat spotted drums, grease spotting, blue drums, scored drums, excessive wear at rivet holes or edges, polished drums, out of round drums, unbalanced drums, worn/damaged brake components, foreign matter in drums. Correct situation or replace defective part(s).
VIBRATION IN RIDE	Defective drums or out-of-round	Replace drums.
	Out-of-balance drums	Balance drums.

Table provided for general use.

NOTES:

Hydraulic System

Most hydraulic system failures follow the same pattern: a gradual or sudden loss of pressure or flow with a resulting loss of cylinder or motor power. Any one of the system's components may be at fault. By following step-by-step procedures, the trouble can be located in a short time.

PROBLEM	PROBABLE CAUSE	SOLUTION
SEMITRAILER LOCKED IN TILTED POSITION	Velocity fuse activated	Raise the trailer slightly (to reset the velocity fuse), then lower the trailer slowly.
SYSTEM INOPERATIVE	Not enough oil in system	Fill, check for leaks.
	Wrong oil in system	Change oil, see specifications ((See "Lubricant Specifications" on page 4-6.))
	Filter dirty or clogged	Drain oil and replace filter.
	Hydraulic lines dirty or collapsed	Clean or replace as necessary.
	Air leaks in pump suction line	Repair or replace as necessary.
	Worn or dirty pump	Clean, repair or replace. Check for contaminated oil. Drain and flush.
	Badly worn components	Examine for internal leakage. Replace faulty components. Check for cause of wear.
	Leakage	Check all components, and relief valve for proper settings.
	Excessive load	Check unit specifications for load limit (See "Standard Specifications" on page 2-1.)
	Slipping or broken pump drive	Repair or replace couplings. Check for alignment
SYSTEM OPERATES ERRATICALLY	Air in the system	Check suction side of system for leaks. Repair leaks.
	Cold oil	Allow ample warm-up time. Use proper weight oil for operating temperature.
	Dirty or damaged components	Clean or repair as needed.
	Restriction in filters or lines	Clean and/or replace filter or lines.
	Not enough oil in system	Fill and check for leaks.
SYSTEM OPERATES SLOWLY	Oil viscosity too high, or "cold oil"	Allow oil to warm up before operating.
	Low pump drive speed	Increase engine speed (check pump owners manual for specifications).
	Low oil level	Check reservoir and add oil as necessary.
	Air in system	Check suction side for leaks. Repair leaks.
	Badly worn pump, valves, cylinders, etc.	Repair or replace faulty component(s) as necessary.
	Restrictions in lines or filter	Clean and/or replace filter or lines.
	Improper adjustments	Check orifices, relief valves, etc. Adjust as necessary.
	Oil leaks	Tighten fittings. Replace seals, gaskets and damaged lines.
SYSTEM OPERATES TOO FAST	Wrong size or incorrectly adjusted restrictor	Replace or adjust as necessary.
	Engine running too fast	Reduce engine speed

PROBLEM	PROBABLE CAUSE	SOLUTION
OVER HEATING OF OIL IN SYSTEM	Oil passing through relief valve for excessive time	Return control valve to neutral when not in use
	Incorrect, low, dirty oil	Use recommended oil ((See “Lubricant Specifications” on page 4-6.)) Fill reservoir with clean oil. Replace filter.
	Engine running too fast	Reduce engine speed.
	Excessive component internal leakage	Repair or replace component as necessary.
	Restriction in filters or lines	Clean and/or replace filter or lines.
	Insufficient heat radiation	Clean dirt and mud from reservoir and components.
	Malfunctioning component	Repair or replace
	Excess oil going to dock level circuit	Adjust flow divider for 2.5 to 3.1 GPM flow.
FOAMING OF OIL	Incorrect, low, or dirty oil	Replace, clean or add oil as needed.
	Water in oil	Replace oil
	Air leaks	Check suction line and component seals for suction leaks. Replace defective parts.
NOISY PUMP	Low, incorrect, foamy oil	Replace, clean, or add oil as needed.
	Suction line plugged	Clean out obstruction or replace line. Flush system, replace filter.
	Pump damaged	Repair or place
LEAKY PUMP	Damaged or worn shaft seal	Replace seal and/or shaft and check for misalignment.
	Loose or broken parts	Tighten or replace
CYLINDERS MOVE WITH CONTROL VALVE IN NEUTRAL POSITION	Leaking cylinder seals or fittings	Replace worn seals or fittings.
	Control valve not centering when released	Check linkage for binding and repair
	Valve damaged	Repair or replace.
CONTROL VALVE LEAKS	Seals damaged or worn	Replace.
CYLINDER LEAKS	Seals worn or damaged	Replace.
	Rod damaged	Replace.
	Barrel damaged	Replace.
CYLINDERS DO NOT FUNCTION, OR CREEP WITH PTO DISENGAGED	Leaking fittings or cylinder seals	Tighten loose fittings. Replace worn seals or fittings.
	Piloted check valve or O-ring leak	Replace defective component.

Table provided for general use.

NOTES:

Document Control Revision Log:

Date	Form #	Improvement(s): Description and Comments
03/07/2024	F-1165-2301	Initial Release



intertek

Equipment from Landoll Company, LLC. is built to exacting standards ensured by ISO 9001 registration at all Landoll manufacturing facilities.

330D

Operator's Manual

Re-Order Part Number F-1165

LANDOLL COMPANY, LLC.

1900 North Street

Marysville, Kansas 66508

(785) 562-5381

800-428-5655 ~ WWW.LANDOLL.COM



Copyright 2024. Landoll Company, LLC.

"All rights reserved, including the right to reproduce this material or portions thereof in any form."

